

FESTOOL

# MAGAZINE.

#5

THE ISSUE FOR CARPENTERS  
AND JOINERS.

AUTUMN  
2023

**TRADITION AND MODERNITY**  
FAMILY BUSINESSES AND PRODUCT FAMILIES  
THROUGH THE AGES.

# FAMILY BUSINESS

**FOCUS** STRONG CRAFT, HEALTHY FAMILY BUSINESSES AND GROWING PRODUCT GENERATIONS 04  
**TOOLS** THE NEW CSC SYS 50 CORDLESS BENCH-MOUNTED CIRCULAR SAW IN A SYSTAINER FORMAT 12  
**TOOLS** EACH MEMBER OF OUR PLUNGE-CUT SAW FAMILY HAS ITS OWN SPECIAL CHARACTER 24  
**DEDICATION** THREE GENERATIONS WORK CLOSELY TOGETHER AT SCHWARZMANN FENSTER GMBH 38  
**LOOK INSIDE** WHY FESTOOL IS GOING ITS OWN CORDLESS WAY 60

# EDITORIAL

**Dear readers,**

In family businesses, more than anywhere else, there is a close connection between tradition and modernity. We have noticed this again and again when visiting customers – most recently, and for this edition of the magazine, at **Schwarzmann Fenster GmbH** in Schopfernau, Austria. Knowledge and expertise are passed on through the generations there, and changes are made from one generation to the next.

The same can be said of our product families, which we are continuously further developing based on our DNA. We do this with the aim of ensuring that the next generation is always the best. This motivation culminates in ground-breaking products, such as our new **CSC SYS 50 cordless bench-mounted circular saw**, with which you can truly achieve workshop quality on the construction site. The most recent member of our plunge-cut saw family, the **TSV 60 K plunge-cut saw with scoring function**, guarantees splinter-free sawing from the first cut. And with the new **RSC 18 cordless reciprocating saw**, you can work significantly more effectively and with noticeably less fatigue during conversion and dismantling.

The fact that we count on innovative technologies and **customised cordless solutions** – that also runs in the family. By tradition and for your future! We hope you enjoy reading our magazine. Be inspired!

Kind regards

A handwritten signature in white ink, appearing to read 'RK', is positioned above the printed name and title.

**René Kruk**  
Managing Director of Festool Germany GmbH

# IMPRINT

## FESTOOL MAGAZINE #5

### Publisher

Festool GmbH

### Festool Editorial Lead

Alma Colbazi-Rebmann

### Editing

RC Redaktionsbüro, Saarbrücken, Germany  
Dr Ralf Christofori

### Art Direction & Layout

Yama Inc, Stuttgart/Berlin, Germany  
Ingo Ditges

### Translation

STAR Deutschland GmbH, Sindelfingen, Germany

### Media services

LOTS OF DOTS MediaGroup. AG, Mainz, Germany

### Cover photo

Sven Cichowicz

© 2023 Festool GmbH

Subject to changes and errors. All images are non-binding. Produced for Festool GmbH, 73240 Wendlingen, Germany, 11/2023.

Reproduction of this text, in part or in whole, is permitted only with the written consent of the publisher.

**festool.com**

Vibration levels and emission values can be found in the operating instructions at [festool.com/operating-instructions](http://festool.com/operating-instructions)

The Bluetooth® word mark and the logos are registered trademarks of Bluetooth SIG, Inc.; they are used by TTS Tooltechnic Systems AG & Co. KG and therefore by Festool, under licence.



Festool is dedicated to taking care of forests for future generations. The following materials are FSC™-certified: paper.

## Festool GmbH

Import Partner Customer Service  
Wertstrasse 20  
D-73240 Wendlingen  
Phone +49 (0)70 24/804-25400  
[customerservice-int@festool.com](mailto:customerservice-int@festool.com)



## UNCOMPROMISING PERFORMANCE

Once you have registered your new tool, it is fully covered for the first three years thanks to our warranty all-inclusive\*. Please note that registration can only be carried out by you, our customers, exclusively in MyFestool\*\*. In MyFestool, you can also see an overview of all your tools, accessories and warranty terms.

Discover all Festool services at:  
» [festool.com/service](http://festool.com/service)

\* Warranty all-inclusive is valid for all Festool tools registered within 30 days of purchase. Please note that the warranty offer may differ depending to country and import partner. The Festool service terms and conditions will apply and are available at [festool.com/service](http://festool.com/service)

\*\* MyFestool is only accessible in countries where Festool Warranty all-inclusive is available.

# CONTENT

# #5

04

**Focus**

## **FAMILY BUSINESS**

In family businesses and product families alike, the next generation is always the best.

12

**Tools**

## **UNIQUELY VERSATILE**

The new CSC SYS 50 cordless bench-mounted circular saw is compact, mobile and extremely precise.

18

**Projects & Work**

## **KING WITHOUT A CROWN**

Our visit to an uncrowned king of timber construction in Oxfordshire, England.

24

**Tools**

## **A TERRIBLY NICE FAMILY**

The strong members of our family of plunge-cut saws introduce themselves.

34

**Tools**

## **THE ENDURANCE RUNNER**

The ROTEX geared eccentric sander has been enriching craft for many generations.

38

**Dedication**

## **FAMILY TIES**

At Schwarzmann Fenster GmbH, tradition and modernity go hand in hand.

44

**Tools**

## **WELCOME TO THE FAMILY**

Festool has the right extractor for every work situation and every application.

46

**Expertise**

## **CLEAN AND HEALTHY WORK**

Effective dust extraction systems are not merely optional but essential.

48

**Favourites**

## **FESTOOL SPOTLIGHTS**

We asked five professional woodworkers about their favourite Festool products.

54

**Inspiration**

## **TALENT SHOW**

Festool supports the talented new generation at EuroSkills and WorldSkills.

56

**Tools**

## **HEAVY BEAM**

The new RSC 18 cordless reciprocating saw is made for the toughest day-to-day applications on construction sites.

60

**Look Inside**

## **THE POWER OF FESTOOL**

Festool relies on customised and intelligent cordless solutions as a system.

66

**Tool tip**

## **FS/2 SET**

Everything that makes the FS/2 guide rail even better in one accessories set!

67

**Imprint**





# FAMILY BUSINESS

05

From generation to generation, families of craftspeople nurture tradition and manage to continuously reinvent themselves. We at Festool, still a family-run company, support them with this – and learn from them. So that you are always one step ahead of the changing times.



↑ One family business, three generations (from left to right): Claus, Jan and Felix Schwarzmann.

## 1. Healthy family businesses.

Family businesses create values that are hard to quantify, but cannot be valued enough.

**R**elevance is not a question of size. Whether large or small – family businesses are a supporting pillar of all national economies. They make up about 60 per cent of all companies in Europe. It would be impossible to determine their value creation in each industry. But this much is certain: In wood construction, family businesses create long-lasting and sustainable tangible and intangible values.

Of course, the changing times are not a sure-fire success. Not in woodworking, and not even in family businesses. Something has to be done to ensure that there is something in it for the next generation. How do you pass on tradition – and how much

of it? What old craft techniques should be preserved? Which new resources or process technologies should be embraced? And last but not least: Which products and product families are worth acquiring in order for daily work to become better and more efficient with each generation?

Claus Schwarzmann, owner of Schwarzmann Fenster GmbH in Schoppernau, Austria, has been grappling with these questions for years. Not in theory, but in practice: "It's our task to maintain the craft and the associated skills, while also exploring new approaches in manufacturing processes," he says. Perhaps the secret to his success lies in this healthy mix. You can read the whole story of this family business on page 38.

# 40-50



Family businesses make up **an average of 40-50%** of all jobs in the private sector in Europe.



Craft has always been family-oriented: **Over 75%** of all businesses are family businesses.

**“WHEN I TOOK THE FAMILY BUSINESS OVER FROM MY FATHER, HE GAVE ME GUIDANCE, BUT GAVE ME SPACE TO WORK. AND THAT’S EXACTLY WHAT I AM TRYING TO DO FOR MY SON. THAT’S HOW WE HAVE MANAGED TO KEEP TRADITION WHILE MOVING WITH THE TIMES.”**

Claus Schwarzmann

# 75



In Germany alone, **around 1 million** businesses count as craft businesses.



# 1000000





**“OUR LONG FAMILY  
TRADITION IS AN OBLIGATION,  
BUT IT IS ALSO INCREDIBLY  
ENRICHING AS WE MOVE  
INTO THE FUTURE.”**

Barbara Austel

**“WE MAINTAIN OUR  
TRADITION, EVEN WITH  
STATE-OF-THE-ART EQUIPMENT.  
I ALSO TRY TO COMMUNICATE  
THIS ATTITUDE TO THE  
YOUNGER GENERATION.”**

Andreas Beck

## 2. Strong craft.

Barbara Austel and Andreas Beck speak about the strengths of woodworking and about maintaining tradition and moving into the future.

**FM:** You both come from family businesses that will soon be celebrating their 100th anniversaries. How much tradition is in your work?

**BA:** My grandfather, Gottlieb Stoll, founded the company Festo in 1925, together with Albert Fezer. His sons, Kurt and Wilfried, took over company management, and his daughter Gerda Maier-Stoll became owner of the Festool brand in 2000. Now I, Berta and Gottlieb Stoll's granddaughter, am working for the company. This long family tradition is an obligation on the one hand, but is also incredibly enriching as we move into the future.

**AB:** It's the same for us. My grandfather founded his own carpentry business in Markdorf in 1925. He was always very modern and, even after the war, constructed turnkey houses, one-and-a-half storeys tall, with the most amazing staircases. My father took over the company in the 1960s. Today, my older brother runs the business. We maintain our tradition, even with state-of-the-art equipment. As master trainer at the Baden-Württemberg timber construction training centre, I also try to communicate this attitude to the younger generation.

**FM:** What exactly does that mean?

**AB:** Woodworking is an extremely traditional craft. The oldest roof trusses that we still use today, are around 1,000 years old. A few weeks ago, in my capacity as an expert, I visited a company in Metz, France, which is reconstructing the 60 metre tall crossing tower of Notre-Dame Cathedral in Paris. There, you can experience traditional wood construction skills up close. And you also learn a lot about the tools and techniques that were used back then.

**FM:** Craft techniques, and in particular the tools, have changed over time. What drives these developments?

**BA:** We are driven by confidence in the strength of the craft along with the motivation that we, as tool manufacturers, are able to actively contribute to this. For us, there are two main aspects in the further development of tools: First, the system concept that not only sets us apart from competitors, but is also highly valued by our customers; and second the exchange with customers, so that we are able to meet their requirements and needs as closely as possible.

**FM:** And do you think that this succeeds, Mr. Beck?

**AB:** I think so. Festool is absolutely innovative – both in terms of individual solutions and clever details as well as the system as a whole. The continuous development of woodworking and the tools goes hand-in-hand. Here in continuing professional development, eyes often grow wider and wider particularly during the machine course, because with the right tools, your work can become so much easier and better. Health protection now also plays an important role in modern businesses.

**BA:** The fact that more than just a cursory thought is spent on how to make daily work easier or how to improve it, also comes down to an appreciation of employees. When I did my joinery apprenticeship over 25 years ago, health protection was an issue, but it wasn't as prominent as it is today. Festool has been at the forefront here for a very long time. And to this day, we are the only tool manufacturer to develop and produce our own mobile dust extractors.

**FM:** Does a strong craft need strong tools?

**AB:** Cordless technology has resulted in huge progress in woodworking. And with increasing digitalisation, further development steps are already pending. We have just had a boom in timber construction, which helped us all a lot, but also demanded a lot from us. That's why it's important not to confuse strength with pure performance and efficiency. I think it's great when somebody does what they do with enthusiasm.

**BA:** And impressive tools can contribute to this. If we manage to achieve that, then we've done a lot right.



**BARBARA AUSTEL**

The granddaughter of the company founder Gottlieb Stoll is active in the company as Partner and Chair of the Supervisory Board of Tooltechnic Systems (TTS) and Festool. The joiner and business economist knows both sides of woodworking.



**ANDREAS BECK**

The carpenter is the master trainer at the Baden-Württemberg timber construction training centre in Biberach an der Riß. He comes from a family of carpenters from Markdorf in the region of Lake Constance, whose business will soon enter its fourth generation.

### 3. Constantly improving products.

Our product families grow from generation to generation. And the following is true: the next generation is always the best.

**F**or us, customers are part of the extended Festool family. This has always been the case, and is perhaps true today more than ever before. When it comes to developing new products or product families, we work for you and with you. As we move towards the market launch, the differentiated and honest assessment of selected test businesses is invaluable. After all: if our customers are happy, then we're happy too.

Of course, this can also be expressed in figures – in technical data and performance records. But the crucial thing is what you want to do, what result you have in mind and how you want to achieve it. That's why we do everything we can to ensure that, with our tools, you can achieve the result you need. And it's also why it's important to us that the system provides you with everything that will make your work easier – not to mention the many clever ideas that cannot be found elsewhere.

The fact that our product family is becoming increasingly digital is a sign of the changing times. But digitalisation is only relevant for us if it creates added value for you. So, the digital operating concept of the new CSC SYS 50 cordless bench-mounted circular saw is already creating a big stir. With our Festool apps\*, you can control functions on the machine, order missing accessories or consumables directly from the construction site or get help if you're stuck with a job. It couldn't be simpler or more convenient.

Saying that the next generation is always the best is therefore not just an empty promise. Because, from generation to generation, our products and product families grow in terms of their tasks and open up unimagined possibilities in terms of new technologies. For us and our customers. For you and your customers.

\* Please note that the Festool apps are not available in all countries.

**“THE FACT THAT WE CAN PUT NEW PRODUCT GENERATIONS THROUGH THEIR PACES IN OUR COMPANY IS FANTASTIC. BUT WE AREN'T THE ONLY ONES TO BENEFIT FROM THIS – THE PEOPLE IN CHARGE OF THE PRODUCTS AT FESTOOL ALSO BENEFIT.”**

Marek Tischner

↓ Innovative: With the CSC SYS 50, the sawing height and tilt of the saw blade can be entered to an accuracy of 0.1 mm via the unique digital display. It moves to position at the push of a button.





↑ The KAPEX KSC 60 battery enables Marek Tischner from IMM AB in Svedala, Sweden, to make unbeatably precise cross cuts – with battery power all day long.

← Two of the latest generation of plunge-cut saws together with the AXF 45 from 1980 – the first plunge-cut saw from Festool (rear right).

**BATTERY POWER.** Few developments have shaped our product generations so much in the last few decades as the battery technology. You can find out more about Festool's journey towards battery power from page 60 of this magazine or online via this QR code:



Scan the QR code to find out more.

# UNIQUELY VERSATILE

Our new CSC SYS 50 cordless bench-mounted circular saw is unique: As precise, powerful and versatile as a large tool, but so compact that it fits in a Systainer. Don't believe it? Then take a look for yourself.

Text: **Melissa Berger** | Photography: **Torben Jäger, Thomas Baumann**

**L**et's be honest: The large machines in the workshop make parallel, cross and angled cuts simple and repeatable. On the construction site, you often have to be content with an improvised approximation. With our new cordless bench-mounted circular saw, that's water under the bridge. Because with this saw, you can actually achieve workshop quality on the construction site. And it couldn't be easier. The CSC SYS 50 produces parallel cuts of up to 280 mm, a cross cut width of up to 450 mm and angled cuts of  $-2^{\circ}$  to  $47^{\circ}$ . With a guaranteed cutting height of 48 mm, all applications typical in interior finishing can be carried out. The 2 x 18 V dual battery system in combination with the brushless EC-TEC motor will impress you with its power and torque – you won't notice any difference compared with mains-powered machines.

The technical data alone speaks for itself. But what the CSC SYS 50 is actually capable of goes far beyond that. The digital operating concept, with which the sawing height and angle can be set to the nearest tenth of a millimetre, is innovative: more exact than with any yardstick, with 100% repeat accuracy. Speeds appropriate for the material can also be preselected via the digital display. And because the idea of workshop quality on the construction site is particularly important to us, we also offer the UG-CSC-SYS rolling underframe for the new cordless bench-mounted circular saw: This allows effortless transport from the vehicle to your work area – so you have the perfect worktable immediately to hand. In this way, you can bring the cordless bench-mounted circular saw to the ideal working height, and with the additional underframe support, you can saw long workpieces accurately, safely and easily.



## Precise sawing to go.

The CSC SYS 50 cordless table saw in Systainer format.

14

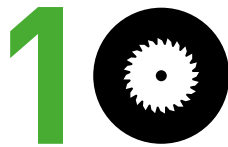

### Precise and variable cuts

The CSC SYS 50 cordless bench-mounted circular saw is convincingly versatile: with parallel cuts up to 280 mm, a cross cut width of up to 450 mm and precise angled cuts of  $-2^{\circ}$  to  $47^{\circ}$ .



### Compact and mobile in use

You can take your compact CSC SYS 50 with you wherever you go – easy to transport by the carry handle of the Systainer cover and even easier with the UG-CSC-SYS underframe.



### Uncompromising battery power

The 2 x 18 V dual battery system in combination with the brushless EC-TEC motor will impress you with maximum power and torque.



5



**Healthy working with a system**  
The CSC SYS 50, in combination with the Festool cordless dust extractors, ensure optimal extraction. The dust collection bag enables dust-free work, even without a mobile dust extractor.

6



**Tidy under the cover**

A practical detail: saw blades, spacer wedges, dust collection bags and even the angle stop are safely stowed in the lid of the Systemainer cover.

4



**Digital configuration and cuts with repeat accuracy**  
You can use the display to electrically adjust the height and angle at the press of a button – accurate to a tenth of a millimetre. You can choose from four saved saw blade settings and save as many additional settings as you want. This means you are guaranteed to cut with repeat accuracy. Linking to the Festool Work App\* enables additional saw blade settings to be saved.

\* Please note that the Festool Work App is not available in all countries.



Experience our new CSC SYS 50 cordless bench-mounted circular saw in action.





**“FLOOR LAYERS WORK EXCLUSIVELY AT THE CONSTRUCTION SITE. THE FACT THAT THEY CAN NOW ACHIEVE SIMPLE AND PRECISE WORK THERE WITH THE NEW CORDLESS BENCH-MOUNTED CIRCULAR SAW IS TRULY REVOLUTIONARY!”**

Nadja Körbel, Festool applications expert

Power output? Comprehensive. Transport? No problem. Precision? Unrivalled. The CSC SYS 50 has what it takes to revolutionise kitchen installation, furniture and interior finishing on-site.

# CSC SYS 50

## **THE NEW CORDLESS BENCH-MOUNTED CIRCULAR SAW**

- › **Impressively versatile.** With parallel cuts up to 280 mm, a cross cut width of up to 450 mm and angled cuts of  $-2^{\circ}$  to  $47^{\circ}$ .
- › **Precise at the press of a button.** You can set the height and angle accurately to a tenth of a millimetre with unique digital operation. It can even make the most challenging cuts with unbeatable precision.
- › **Durable power.** The CSC SYS 50 offers mighty power and torque – even for rip cuts in solid wood.
- › **Compact and mobile.** Can be transported with one hand in the practical Systainer format – and it's even easier with the UG-CSC-SYS underframe.

## **FIND OUT MORE**

You can find out all about the new cordless bench-mounted circular saw, the sets and the entire system on our website:  
› [festool.com/@577374](https://www.festool.com/@577374)

# The CSC SYS 50 in the system. Mobile sawing just like in the workshop.

The UG-CSC-SYS underframe developed for the CSC SYS 50 is just as brilliant as the CSC SYS 50 itself. And almost indispensable. For rolling transport or at work. Not to mention the many clever accessories and system components with which you can achieve the usual workshop quality even on the construction site.



### Underframe

The UG-CSC-SYS underframe is the ideal worktable for the new cordless bench-mounted circular saw, and with the additional underframe support, you can saw long workpieces accurately, safely and easily. In addition, the rolling underframe is the ideal solution for transport from the vehicle to the construction site.

### Energy set

If you make sustained demands of our new CSC SYS 50 with double battery system, you can continuously recharge it with the energy set.

### FESTOOL WORK APP\*



With the Festool Work App\*, you can connect your tools and battery packs easily and, with the CSC SYS 50, you can even save and retrieve saw blade positions.

\* Please note that the Festool Work App is not available in all countries.

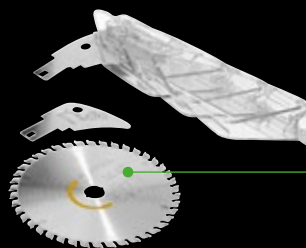

### Saw blades

With the launch of the CSC SYS 50, the TSV 60 and the TS 60 K, we indulged ourselves and you with new saw blades with a 168 mm diameter. So you can achieve the best results in any material.



# KING WITHOUT A CROWN

Mark Maxfield lives and works in the Cotswolds, which are considered to be the “Heart of England”. He might not be an avowed royalist, but he’s a Festool fan through and through. At a construction site that is anything but usual, he tells us why.

Text: **Ralf Christofori** | Photography: **Simon-Paul Schempershofe**



**WITNEY, OXFORDSHIRE**

**51° 47' N | 1° 29' E**



↑ When working on site, Mark Maxfield prefers to use his HK 85 with the SYS-PowerStation and the SYS-PowerHub.

← He installs the new CSC SYS 50 cordless bench-mounted circular saw on the underframe incredibly quickly – and can get started immediately.



**“WHAT I REALLY LIKE ABOUT THE NEW CORDLESS BENCH-MOUNTED CIRCULAR SAW IS THE DIGITAL PRE-SETTING. THIS MEANS I CAN SET TWO DIFFERENT CUTS ON ONE WORKPIECE AT THE PUSH OF A BUTTON. AND IT’S ULTRA PRECISE.”**

Mark Maxfield

It is the start of May. Two days before the coronation, the whole world is watching London. We have an appointment with an uncrowned king of timber construction, about two hours by car to the west of London. On our way through a picturesque village in the Cotswolds, the streets become noticeably narrower and the houses increasingly English. At the entrance to our destination, Mark Maxfield is waiting for us. He is a man of impressive stature and greets us warmly. When he opens the rear doors of his van, he beams even more: There are Festool Systainers and machines, batteries and rapid chargers, extractors and multifunction tables from the floor to the ceiling; and a fixed workbench too. "Welcome to my workshop!" says Mark, explaining: "I work almost exclusively on the construction site. So I always have everything I need here with me in my van."

### Far more than just a construction site

"Construction site?" You have to wonder if you can actually call this premises, which Mark Maxfield has been restoring and modernising for more than four years now, a construction site. It consists of a vast park as well as several residential and outbuildings, some of which are over 400 years old. In consecutive building sections, the main building and the former barn were fully renovated and redesigned, and a small outbuilding was converted into a guest house with lots of attention to detail. In 2019, when it all kicked off, Mark was employed as the site manager. He knows what works – and how. Whether its the restoration and preservation of original building substance, the construction of an outdoor pool or drilling for two 9,500 litre underground fresh water tanks.

The skilled joiner and carpenter is in his element when it comes to wood. He is currently working on the roof truss of a long, narrow shed, which is to be used as a fitness room and outdoor eating area from the summer. With expertise and sensitivity, he tries to maintain as much original material as possible. "Depending on the condition, we have even succeeded in doing this with the beams and girders from the other building," explains Mark, "occasionally we have even hollowed out the girders and reinforced them with synthetic resin or steel." However, there was not much of the shed's old roof truss left to save. So, for the new development, he recalled an old timber construction technique that works entirely without screws, nails or metal anchors: stands, purlins and head bands are mortised and secured with strong oak dowels.

### Traditional techniques and modern tools

"This type of project is a constant reminder of the wonderful tradition of your own craft. But when I unpack my machines and start them up, I can really appreciate how easily and precisely work can be done today," says Mark Maxfield happily. In the blink of an eye, he sets up a small machine park in the shed. He uses the large HK 85 nearly every day. The SYS-PowerStation together with the SYS-PowerHub supplies the plunge-cut saw with plenty of power. And because he also wants to be mobile



↑ Stands, purlins and headbands are mortised based on historical examples and secured with turned oak dowels.

↓ Anything other than ordinary – the journey to the construction site goes through a well-tended English lawn.

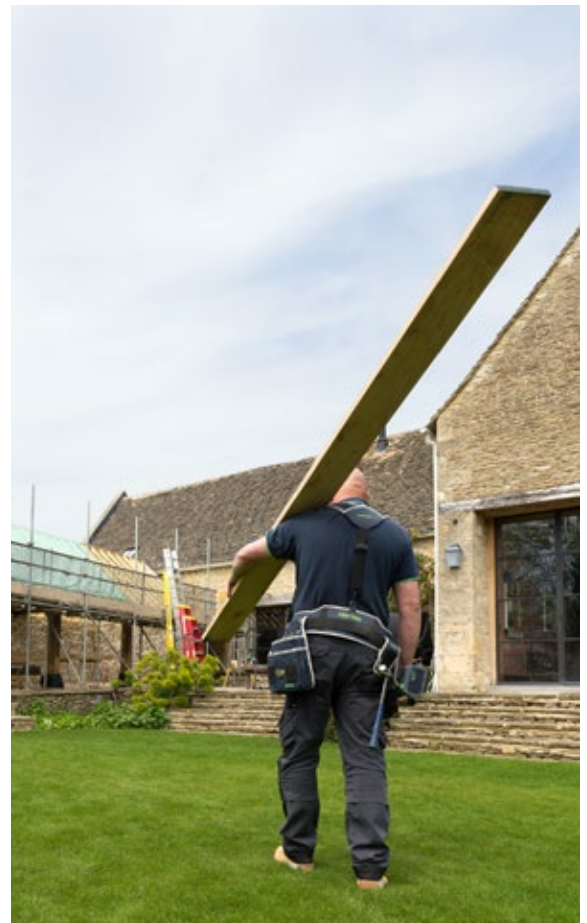

and independent when it comes to dust extraction too, he has purchased the new CTC MIDI cordless extractor. "In the early years, it took a lot more effort to do a good job. But since I've been working with Festool tools, I really look forward to working with my machines," says Mark.

22

At first he wasn't interested in getting his most recent acquisition, but now he genuinely raves about it. A close friend and valued colleague told him about the new Festool CSC SYS 50 cordless bench-mounted circular saw. "I immediately waved it aside," recalls Mark, "but then he came to me and let me try it out. Two hours later, I had ordered it." Mark Maxfield is a man of conviction, who is not easy to convince. But when he falls in love with a machine or a tool, it's true love.

→ Customised kitchens, beds and wooden staircases – the joiner's craft skill was in particular demanded for interior finishing.

↓ View from the main building across to the former barn and the shed, which is under construction.





### Perfection as the result of skillful craftsmanship

There's no doubt that Mark loves his job. The precision with which he has fitted customised solid wood kitchens into the historical walls here is more than impressive. From the static, freely suspended staircases to the fine wood panelling – at the end of the day, perfection is not a question of style for Mark Maxfield, but the result of his skillful craftsmanship. And all the while, the uncrowned king of timber construction has a royally good time!

You can find out more about Mark Maxfield and his extraordinary timber construction projects in our video in English:  
» [festool.com/crown](https://www.festool.com/crown)

↑ It doesn't take much imagination to see that Mark Maxfield is an avowed Festool fan. He always has everything with him in his van.

↓ Mark is at least as enthusiastic about Festool's service and digital tools as he is about its tools.



### MAXFIELD'S

Even as a 12 year old, Mark Maxfield wanted to become a carpenter. In 1982 he started his apprenticeship and then spent almost a year working in a joinery. He then switched to a construction site, worked in the historical colleges of Oxford University, and then worked throughout the country on various construction sites for the same company for 34 years. Over time, he realised that he wanted to do his own thing: be free, try things out, learn new things. In 2014, he founded his own company Maxfield's in Witney and has been working on some of the most amazing projects and properties ever since.





# A TERRIBLY NICE



**TSV 60 K**

**TS 60 K**

**TSC 55 K**

**TS 55**

**TS 75**

In the best of families, everyone has their own mind – you could even say their own character. This applies equally to the dyed-in-the-wool fans in our Festool family and to the members of our product family. But everyone has their own answer as to why they like working best with which plunge-cut saw.

Text: **Ralf Christofori** | Photography: **Thomas Baumann, Jan Zawadil, Simon-Paul Schempershofe, Igor Dziedzicki, Emily Harris**

# FAMILY





Enthusiastic faces with wide eyes; cutting results that are acknowledged with a nod of recognition: Since 1980, Festool plunge-cut saws have been known for their reliable quality and absolute precision. And the family is growing continuously.

## The perfectionist.

Splinter-free in the first cut.

**W**hen we speak about our plunge-cut saw family, then we're always talking about Festool's DNA. Our aim: The perfect cut. Our objective: Tools that will astonish even dyed-in-the-wool professionals. With the TSV 60 K plunge-cut saw with scoring function, we have perfected both. Splinter-free sawing on both sides now from the very first cut. With the TSV 60 K, workshop-quality results can be replicated on the construction site – as good as with a stationary machine. Coupled with the built-in KickbackStop, you and your workpiece are protected from dangerous kickbacks and thanks to the ideal combination of Festool system accessories, your work can always be precise and tailored to requirements, even when on the move. The extensive system completes the ingredients for perfect panel cutting.

The Festool TSV 60 K plunge-cut saw with scoring function offers a clear edge – in woodcutting and in modern materials. The TSV 60 K was practically made for cutting façade panels made from high-pressure laminate (HPL). Its two-sided, splinter-free cutting in just one work step is impressive. The scorer also ensures a longer life of the main saw blade. Andreas Rilli from the Frank Wilhelm carpentry shop in Filderstadt confirms this: "We are able to saw 350 m with one saw blade! Normally, we only manage 150 m. Every craftsperson who works on façade panels should have one of these machines!"

← Who can do without the TSV 60 K plunge-cut saw with scoring function for splinter-free panel cutting? Not Andreas Rilli from the Frank Wilhelm carpentry shop in any case.

# TSV 60 K

27

### TSV 60 K PLUNG-CUT SAW WITH SCORING FUNCTION

- › **Perfection from the first cut.** The TSV 60 K plunge-cut saw with scoring function together with the scoring saw blade ensures two-sided, splinter-free cuts in just one work step. The track and depth of the scorer unit can be set precisely.
- › **Permanently perfect cutting quality.** The diamond scoring saw blade guarantees a very long service life and perfect cut quality time and time again.
- › **High cutting power.** 60 mm cutting depth and the thin cutting saw blades enable effortless progress with low physical strain.
- › [festool.com/@576730](https://www.festool.com/@576730)



### Greater safety when sawing – thanks to KickbackStop

The unique KickbackStop reduces the risk of injury caused by kickback during sawing or plunge-cutting into the workpiece. After the cartridge has been triggered, the saw is ready to use again straight away without replacements or additional costs.





↑ For Gerben Evers, it is crucial that every single cut is absolutely precise – even in thick materials.

## The all-rounder.

Saws like a hot knife through butter.

**G**erben Evers is a specialist in wooden doors. As a sole trader, he does nearly everything himself. The Dutchman says his “most important ‘employees’” are his tools. He has known the TS 60 K plunge-cut saw for longer than it has been on the market. Why? Because Gerben Evers put it through its paces as a test customer. The TS 60 K is practically made for his tailor-made products: precise, efficient and extremely versatile in combination with the cross cutting guide rail. The “K” for KickbackStop particularly impressed him: “No matter how hard you concentrate when working, the saw blade can still occasionally catch. The KickbackStop function reacts immediately. It’s really impressive.”

# TS 60 K

## TS 60 K PLUNGE-CUT SAW

- › **One for all.** The TS 60 K is our most versatile plunge-cut saw. With its 60 mm cutting depth and compact design, it offers premium results even when working with mitre cuts and solid worktops.
  - › **Powerful and precise.** The new TS 60 K works with absolute precision. The high speed ensures ideal machining, an effortless feed rate and the best cutting quality.
  - › **Robust and virtually maintenance-free.** The TS 60 K is extremely robust under any conditions. The new-generation, brushless EC-TEC motor is virtually maintenance-free.
- › [festool.com/@576721](https://www.festool.com/@576721)



## The mobile option.

As powerful as a corded tool.

**F**loor Doelman is a real doer. The clue is in her Instagram account "Floor maakthet", but a quick glance into her workshop also gives her away. There, the young wood designer from Delft in Holland creates individual pieces of furniture and objects from old wood. She uses Festool machines to turn her creative ideas into a reality.

"I like to work with solid wood, so my cordless plunge-cut saw needs to be able to really perform. I can completely rely on it.", enthuses Floor Doelman. The TSC 55 K is perfect for her purposes. It is precise, persistent and has lots of power. Just like Floor Doelman.

# TSC 55 K

29

### TSC 55 K CORDLESS PLUNGE-CUT SAW

- › **Mobile and independent.** The new TSC 55 K cordless plunge-cut saw is as powerful as a mains-operated machine, but completely untethered.
  - › **Powerful and durable.** The tried-and-tested dual battery system (2 x 18 V) combined with the brushless EC-TEC motor delivers maximum power and a longer service life.
  - › **Even safer.** The unique KickbackStop function reduces the risk of injury caused by a kickback during sawing or plunge-cutting into the workpiece.
- › [festool.com/@577342](https://www.festool.com/@577342)

↓ With battery and KickbackStop:  
The TSC 55 K plunge-cut saw is first  
choice for Floor Doelman.



## The solid option.

Simply precise – day after day.

30

**T**he Polish joiner Alicja Solarska works under the professional name “Alice in the Woodland”. “I wanted the name to create a link to fairy tales. Except that my magic wands are the power tools,” she says with a wink. Alicja knows exactly what she’s doing and is a hard worker. A whole series of Festool machines help her with her work – including the TS 55. “I like working with different types of wood. But I remain faithful to this saw: the TS 55 is a reliable partner for me in almost all projects.” Why? Because the TS 55 now saws up to twice as fast and, in combination with the new saw blade generation, guarantees perfect cut quality with maximum cutting power.

↓ Alicja Solarska’s favourite TS 55 plunge-cut saw is just as versatile and discerning as she is.

# TS 55

### TS 55 PLUNGE-CUT SAW

- › **Legendary reliability.** The TS 55 has always stood out with its absolute precision cuts, maximum power and extreme durability.
  - › **Twice as quick.** Concentrated torque and up to twice as fast work progress with an extended saw blade service life.
  - › **Exceptional results.** With accessories like guide rails, angle stops or the splinter guard as well as with extraction ideally suited to the machine, the TS 55 is an exceptional saw system – for any challenge.
- › [festool.com/@576703](https://www.festool.com/@576703)





↑ Alen van Rooyen relies fully on the TS 75 for accurate cutting of cedar wood.

## The large option.

With depth and power.

**I**n the beginning there is a mighty piece of wood. Alen van Rooyen starts the TS 75 plunge-cut saw and makes a cut. With power, depth and precision. The surfboards produced by the founder of the British surfboard manufacturing firm Lignum in South Devon are made of a special wood: Western Red Cedar. It's not easy to work with cedar wood. Knowledge of the tools and the properties of the wood are crucial in order to achieve the desired result. And Lignum makes no compromises there. "We manufacture high-quality products from a challenging material. To do this, we need the right tools," stresses Alen. And of course the TS 75 plunge-cut saw is one such tool.

# TS 75

### TS 75 PLUNGE-CUT SAW

- › **Powerful yet effortless.** With a 75 mm cutting depth and 1,600 watts, the TS 75 can handle even thick workpieces with a single cut.
  - › **Convenient and reliable.** With quick-acting brake system for safe, convenient sawing. The spring-mounted guide wedge prevents kickback, minimising the risk of injury.
  - › **Precise and adapted to the material.** Exact plunge cuts to the nearest millimetre and at the right angle. Optimal adaptation to the material and therefore very versatile in the application area.
- › [festool.com/@576110](https://www.festool.com/@576110)



## Our plunge-cut saw family. Your choice.

You decide which suits you best.

32

**TSV 60 K**  
The perfectionist



60 mm cutting depth  
Cable power supply  
KickbackStop technology

**TS 60 K**  
The all-rounder



60 mm cutting depth  
Cable power supply  
KickbackStop technology

**TSC 55 K**  
The mobile option



55 mm cutting depth  
Battery power supply  
KickbackStop technology

**TS 55**  
The solid option



55 mm cutting depth  
Cable power supply

**TS 75**  
The large option



75 mm cutting depth  
Cable power supply

Here is another overview of all the plunge-cut saws.



## Your plunge-cut saw. Our saw blades.

The right blade for every material.

### WOOD UNIVERSAL

The all-rounder for working with all types of wood and wood materials, as well as building panels and soft plastics.

### LAMINATE/HPL

Ideal for laminate and melamine-resin-bonded panels (such as Trespa®).

### ABRASIVE MATERIALS

The problem solver for cement and gypsum-bonded particle boards.

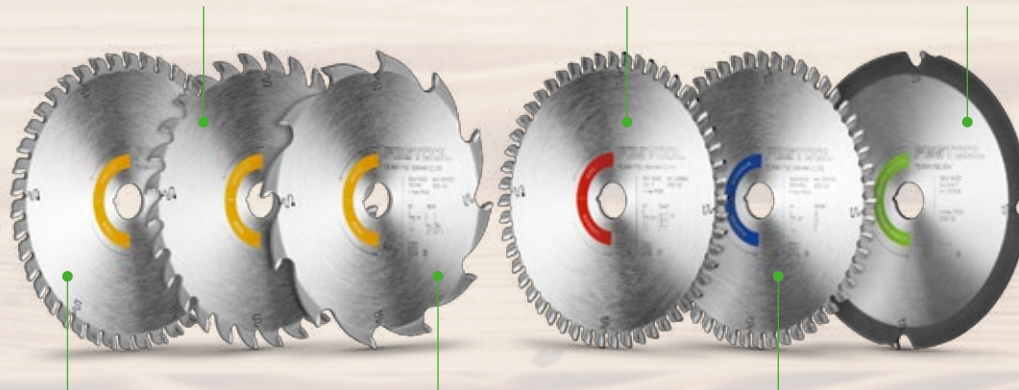

### WOOD FINE CUT

The fine-cut blade for clean and splinter-free cross cuts in solid wood, laminated or veneered sheet materials and acrylic glass.

### WOOD RIP CUT

For fast working with little effort, especially for rip cuts in solid wood. Suitable for both hardwood and softwood.

### ALUMINIUM/PLASTICS

Highly suitable for aluminium sheets and profiles as well as fibre-reinforced and hard plastics.

You can find out all about our new saw blades on our website:  
» [festool.com/circular-saw-blades](http://festool.com/circular-saw-blades)

## Useful system accessories.

Everything that makes sawing easier for you.

### FS-PA parallel side fence

With the FS-PA parallel side fence, you can cut equally wide strips of up to 650 mm simply, precisely and with repeat accuracy when cutting panels.

### FS-WA angle stop

For precise and rapid angle cuts with repeat accuracy and high precision, from  $-60^\circ$  to  $+60^\circ$ . The angle stop therefore offers a wide range of applications and full flexibility.

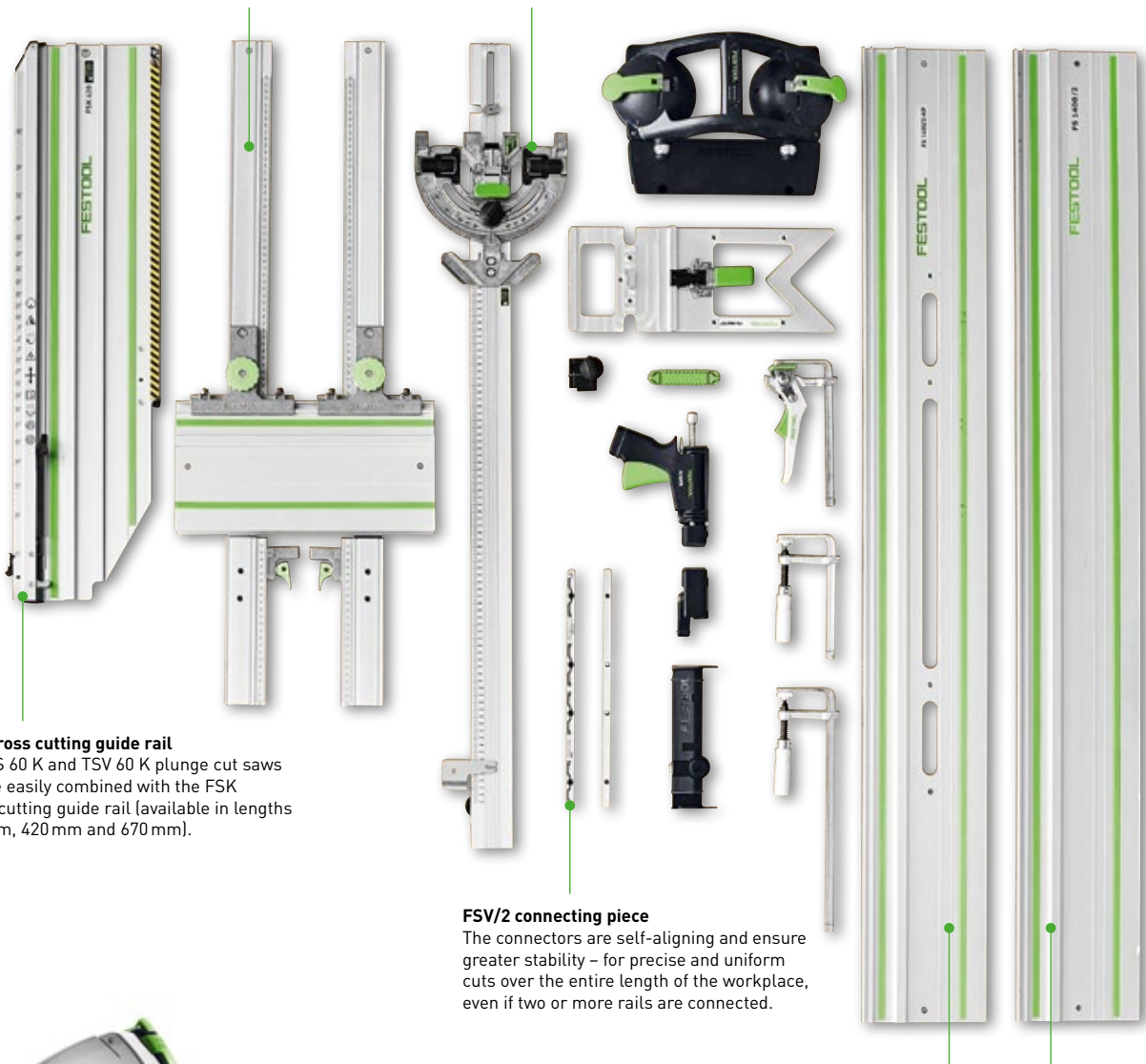

### FSK cross cutting guide rail

The TS 60 K and TSV 60 K plunge cut saws can be easily combined with the FSK cross cutting guide rail (available in lengths 250 mm, 420 mm and 670 mm).

### FSV/2 connecting piece

The connectors are self-aligning and ensure greater stability – for precise and uniform cuts over the entire length of the workplace, even if two or more rails are connected.

### FS & FS/2-KP guide rails

Always saw straight with precision and stability – with the guide rail you can do this on a length of up to 5m, and with the FS/2-KP and the new adhesive pads, you can even do this on a vertical wall.



### PIZZ-TS pizza cutter

For anyone who doesn't want to miss out on a stylish plunge-cut saw even while eating: the TS 60 K as a pizza cutter (manual operation and without KickbackStop).





**THE**

**ENDURANCE**

**RUNNER**

The ROTEX has already made several generations of craftspeople happy. In 1979, experts marvelled at the RO 1 – to this day, the ROTEX RO 150 is the unrivalled master of versatility.

Text: **Ralf Christofori**  
Photography: **Festool USA, Thomas Baumann**

**T**he ROTEX is an endurance runner in two senses of the word: For more than forty years, it has been impressing professionals and discerning craftspeople in equal measure. The robust geared eccentric sander is also considered to be extremely durable and almost indestructible. Its talents as an all-rounder are truly legendary: Three tools in one, that can handle coarse sanding with a mighty material removal capacity as well as fine sanding and even polishing – that's something that has never existed before. And delight at the ROTEX has still not waned.

The RO 1 proved that it was a big success already at the end of the 1970s. In 2005, the RO 150 was launched: noticeably more ergonomic and equipped with a more powerful motor. Thanks to the double-sealed long-life gearbox, the RO 150 is even more durable. It too does the work of three tools, but makes work on large areas even easier.

Over the years, ROTEX formed its own small family passing on its best genes to the RO 90 and RO 125. The latter is ideal for jobs in which a lighter and handier tool is required. The ROTEX RO 90 even combines four tool functions in one machine, because it can be converted into a Delta sander with the corresponding triangular pad.

## Best genes

Giving woodworkers the right tool for every surface application – that's something Festo and Festool have always been able to do. But combining several tools in one sander was something nobody had achieved before the ROTEX RO 1.

35



**1966**

### RTT-S ORBITAL SANDER

Sanding goes dust-free: The RTT-S was the world's first orbital sander with a dust extraction connection.



**1976**

### WST 150 ECCENTRIC SANDER

Greater material removal capacity than ever before: The first eccentric sander with integrated extraction was brought to market.



**1979**

### ROTEX RO 1

Two in one: The option to switch from coarse to fine sanding makes it easier for the craftsman to switch between working steps.



**2005**

### ROTEX RO 150

From evolution to revolution: The RO 150 geared eccentric sander combines three sanding functions in one machine: coarse sanding, fine sanding and polishing.

## It can do everything – and really well too.

The ROTEX RO 150 can be used for coarse sanding, fine sanding and even polishing. This makes the geared eccentric sander a versatile all-rounder.

36



### MULTI-JETSTREAM 2

The patented MULTI-JETSTREAM 2 pad with supply air and exhaust air ensures maximum extraction with maximum sanding power. Available in ultra-soft (SW), soft (W) and hard (H) hardness levels.

### THE ROTEX ROTARY MOTION

The unique ROTEX rotary motion is a combination of orbital and eccentric motion. It guarantees outstanding sanding results in particular when sanding with high material removal (coarse sanding) and when polishing.

#### Coarse sanding

Maximum material removal with the ROTEX rotary motion: The displaced orbital and eccentric motion removes large quantities of material in no time at all.

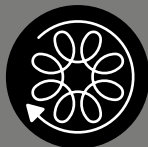

#### Fine sanding

The classic eccentric motion for intermediate and fine sanding achieves a super-fine sanding finish and ensures top class surface quality.



#### Polishing

The ROTEX rotary motion combined with Festool polishes and polishing sponges produce gleaming results without heating the surface significantly.

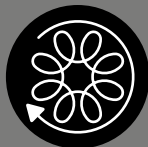

### PROTECTOR

The FESTOOL 150FX protector protects the sanding pad and the workpiece. Especially when sanding close to the edge, the protector offers protection against damage directly at the edge of the workpiece, thus avoiding laborious reworking.



### MORE PRESSURE

Using the BG-RO 150 handle, you can apply even pressure to the surface and build up more pressure while polishing. In addition, less heat radiates from the gearbox to your hand during polishing.



### EVERYTHING WITHIN REACH

With the ZG-RAS/RO auxiliary handle, it's easier to guide the machine – especially during coarse sanding work with the ROTEX RO 150, but also during careful fine sanding and polishing.

### EFFECTIVE EXTRACTION

For coarse and fine sanding, the effective dust extraction in combination with the right CLEANTEC mobile dust extractor is a must. For unhindered polishing, the extraction channel on the machine can be removed with one hand.



All-rounders are usually able to do everything to a fair standard, but not really well. The ROTEX RO 150 is completely different. Its high-torque motor achieves a high material removal capacity during coarse sanding and outstanding surface qualities during fine sanding. The ROTEX rotary motion, the proven combination of eccentric and orbital motion, enables the RO 150 to achieve perfect results even when polishing high-gloss paint or oiled surfaces.

The speed control allows the tool to be adjusted perfectly according to the particular material properties and surface quality. The switch between coarse and fine sanding is achieved via the switch positioned on the handle cap. The toolless retrofitting of the sanding pad or polishing pad is child's play, thanks to the FastFix system. And, of course, effective dust extraction is indispensable during coarse and fine sanding. That's why Festool has developed the world's only MULTI-JETSTREAM sanding system: The sanding pads work via supply air and exhaust air, in order to prevent the formation of a vacuum on the workpiece. And, at the same time, the pad and abrasive are cooled, which further increases their service life. All this and more makes the ROTEX RO 150 a timeless modern classic to this day.

# RO 150

37



## GEARED ECCENTRIC SANDER

- > **Multifunctional legend.** By using the ROTEX, you can perform three different operations without changing devices: Coarse sanding, fine sanding and even polishing.
- > **Fast changeover.** Quick and easy to change attachments or switch between functions. Change pads quickly without the need for tools thanks to FastFix.
- > **Outstanding results.** Extremely high material removal capacity for coarse sanding, super-fine pattern for fine sanding and a perfect finish when polishing.
- > **Systems get it done.** Sanding pads in a range of hardnesses and abrasives which are perfectly adapted to the pad and extraction – for any surface application.

## FIND OUT MORE

You can find out all about the ROTEX 150 and its smaller siblings on our website:

>> [festool.com/@576017](https://www.festool.com/@576017)

## #festoolme

Share your Festool moment with us on Instagram.

 [instagram.com/festool](https://www.instagram.com/festool)

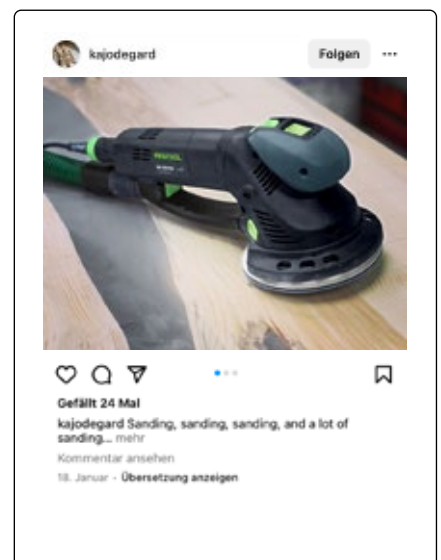
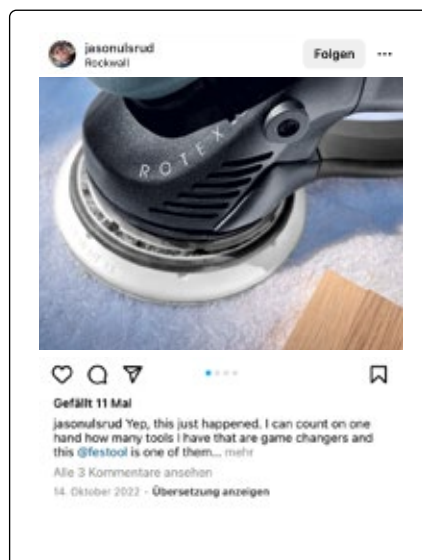
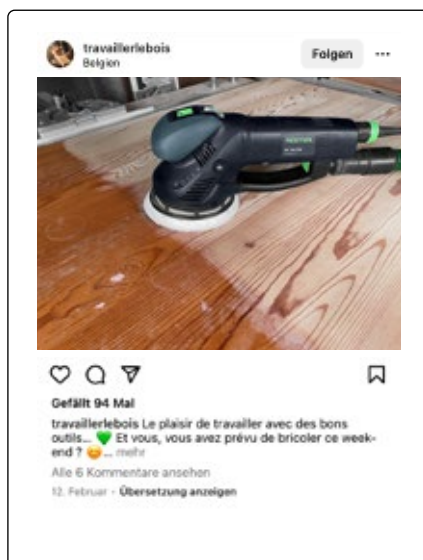



**SCHOPPERNAU**  
47° 19' N | 10° 1' E



# FAMILY TIES

Schwarzmann Fenster GmbH in Schopfernau, Austria, is at the cutting edge of its field. Felix Schwarzmann, the founder, was always an innovator. Claus and Jan Schwarzmann are successfully leading the family business into the future. It's impressive how closely the three generations work together. In good times and bad.

Text: **Ralf Christofori** | Photography: **Sven Cichowicz**



**S**ome sequels are told from the certainty that there will be a happy ending. This is one of those stories. It begins in April 2021, on our first visit to Schwarzmann Fenster GmbH in Schoppernau in the lower part of Bregenz Forest. And it continues two years later, on our second visit in April 2023. Right in the middle is a date that the Schwarzmanns will never forget: 26th April 2022.

But back to the beginning. In April 2021, we met for the first time, with three generations at one table. Felix Schwarzmann told us how he founded the joinery in Schoppernau 50 years ago when he was in his mid-twenties. The workshop was in the ground floor of a residential building. Even back then, the focus was on window construction. Demand rose and new employees were taken on. In 1981, his son Claus began a joinery apprenticeship in his father's business. The Schwarzmanns have always been innovative. By the mid-1980s, a programmable computer had become part of the inventory. In 1996, the first digital window fitting angle system was acquired. The family company is constantly growing. When Jan was born, the next generation saw the light of day. "Of course, I didn't know my luck back then," he grins, "but apparently, even as a young boy, I was always writing that I wanted to be a joiner when I grow up." In the meantime, he has become a master craftsman and junior manager.

#### Traditional craft meets technological expertise

Over the years, Schwarzmann Fenster GmbH has perfected the production of extraordinary solid wood windows: from a long-standing tradition of woodworking in Bregenz Forest; and with state-of-the-art machines that have opened up even more possibilities in the business in terms of quality and precision. For instance, the large CNC router is used to route window profiles with very complex geometries with millimetre precision. Right next to it, there is also a large number of Festool sanders and cordless screwdrivers used by workers. Here and there, some rework is done by hand.

"It's our task to maintain the craft and the associated skills, while also exploring new approaches in manufacturing processes," says Claus Schwarzmann. That's precisely why the Schwarzmanns are building an extension with modern air circulation and a separate wood store. The building, a huge hall with a high gabled roof, will be completed by spring 2022. The façade walls of the previous workshop will open towards the new factory hall. And of course, production will continue throughout.

**"APPARENTLY, EVEN AS  
A YOUNG BOY, I WAS  
ALWAYS WRITING THAT  
I WANTED TO BE A JOINER  
WHEN I GROW UP."**

Jan Schwarzmann

→ The Schwarzmanns produce high-quality "windows to the world". In the new factory hall, you get a fantastic impression of what that actually means.

↓ Felix Schwarzmann and his grandson Jan are working together on the installation of a traditional lattice window.







↑ At Schwarzmann's, "manual labour" is just as in demand as the use of Festool professional tools.

← The CNC router makes it easier to produce highly complex and precise frame profiles on a large scale.

↓ In the end, precision work and top quality count – and Schwarzmann windows vouch for this with their name.



### A life-changing experience that demands everyone to give their all

Everything is going to plan. That is, until the night of 26th April 2022, when the infamous small spark triggers a catastrophe. Starting from the CNC router, which was working overtime on this particular evening, a fire spreads quickly. Felix noticed it first and tried in vain to put the fire out with the fire extinguisher. When the fire crippled the electrics, everything went pitch black and the 82 year old was just about able to feel his way outside. His son Claus called the fire brigade immediately. The men move in with fire trucks, among them a particularly brave soul, who wants to enter the building immediately. On taking a closer look, Claus realises that it's his son Jan under the fire brigade helmet.

"We were so happy that nobody was harmed," remembers Claus Schwarzmann "It was only in the coming days that the full extent of the destruction became clear. But the great thing was that none of us had lost the hope or confidence that we would build everything up again." The next year was extremely demanding on the Schwarzmanns. But it also brought them together. "We are so thankful that everybody helped us – our employees, our families and, above all, our colleague Andreas Böhler, who offered to let us continue production in his factory hall immediately after the fire."

### Families ties with origin and with future

It's a minor miracle that there are no traces of all this in April 2023. Production has resumed. "The new CNC router is even more variable, precise and powerful. The Festool tools that survived the fire have all been cleaned, repaired and tested by Festool Service," explains Jan. The eccentric sander, extractor and screwdriver are all fully in use again. And Felix Schwarzmann already has the next tool on his personal wish list: "I'm going to buy the new RSC 18 cordless reciprocating saw right away," he gushes.

It's lovely to see that the three have retained their enthusiasm for and dedication to what they are doing. Claus speaks about important virtues that he learnt from his father and has passed on to his son. Perhaps there's even a specific gene that runs in the Schwarzmann family. Some call it tradition. Others call it the future. In any case, it's inconceivably valuable.

For more impressive stories from the world of woodworking, see our blog:  
» [festool.com/blog/work](https://festool.com/blog/work)

### SCHWARZMANN FENSTER GMBH & CO. KG

The family business from Schoppernau, Austria, produces high-quality windows, doors and shutters – primarily from domestic spruce and fir wood. Founded in 1971, three generations now work hand in hand. The business has 11 employees.

**"IT'S OUR TASK TO MAINTAIN THE CRAFT AND THE ASSOCIATED SKILLS, WHILE ALSO EXPLORING NEW APPROACHES IN MANUFACTURING PROCESSES."**

Claus Schwarzmann

↓ After a difficult year, Claus Schwarzmann is all the happier about his new factory hall.



## Welcome to the family.

44 Our CT extractors are part of the dust extractor family. And, as in any family, they all have their specific roles. Here, we introduce some of the members and their strengths.

### CTC SYS

#### The cordless service extractor.

Our cordless extractor in Systainer format is like a little brother who loves to be carried on your shoulders. Whether on scaffolding or on a ladder – the CTC SYS performs well in small installation and service jobs.



### CTC MINI & MIDI

#### The compact cordless extractor.

If you experience our CTC MINI & MIDI cordless extractor in action, you'll notice that it is really compact, manoeuvrable and always on the move. It also offers outstanding suction power.



### HIGH-POWER BATTERY PACK

#### BP 18 LI 8.0 HP-ASI

#### Greater battery power and endurance

The new 8.0 Ah battery pack provides tremendous power and endurance and in doing so ensures a 60% longer running time than a 5.0 Ah standard battery pack – including in our CTC MINI & MIDI cordless extractors.

### CT 15/25

**Highly motivated cleaners.**

Our two young cleaning extractors – with either 15 or 25 l tank volume – are happy to lend a helping hand when you want to leave your construction site or vehicles clean. They extract dust, dirt and even water.



### CT 26/36 AC

**High performer with dedusting.**

Our CT 26/36 AC mobile dust extractors are like older siblings: experienced extractors with a large tank volume and high flexibility. Thanks to automatic AUTOCLEAN (AC) filter dedusting, the extractors are ideally suited to fine mineral dust, and they operate at a constantly high suction power.



### CT 26/36/48 E

**Undisputed family chief.**

First choice for extraction of wood dust and wood chips, e.g. when sawing, planing or routing – on the construction site with 26 l tank volume or in the workshop with an impressive 48 l tank volume. The compact high-performance turbine delivers 3,900 l/min volume flow, so nothing remains except clean air.

## Find the right extractor

Whether there is a lot of dust or just a little, whether it's dust in a workshop or dust from installation work, wood, paint or something else. We will help you find the right extractor for your purposes: with our online application consultant.

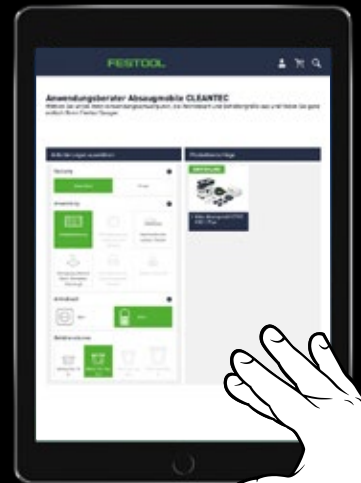

Scan the QR code and start the application consultant.

## Clean and healthy work.

Dust in the workplace is a nuisance – and it poses health risks for you. Dust extraction systems are therefore not merely optional but essential. We have put together everything worth knowing for you.

### DUST CONCENTRATION

There are maximum allowable concentrations for harmful dusts. These define the maximum concentration of dust in the air we breathe, at which no negative health effects would be expected during a 40-hour working week.

### DUST CATEGORIES

Dust categories are crucial. They indicate the suitability of the extractor for the respective types of dust. And they define the required filtration efficiency of the corresponding filter systems.



**Suitability:** Harmless dust such as household dust, as well as materials such as soil.  
Filter system filtration efficiency > 99%



**Suitability:** Harmful dust such as all wood dust or dust from putty, filler, cement and varnish.  
Filter system filtration efficiency > 99.9%



**Suitability:** For carcinogenic and pathogenic dust, such as asbestos and mould.  
Filter system filtration efficiency > 99.995%

### SYMPTOMS

- **Coarse dust particles** are generally caught by the nasal hairs or the mucous membranes of the nasopharyngeal space but can cause diseases and irritation there too.
- **Fine dust particles** which are inhaled can penetrate as far as the alveoli (air sacs) and cause serious diseases, such as asthma, chronic bronchitis or even cancer.
- **Harmful dusts** in the air can – depending on the pollutant content – also cause irritation or allergic reactions of the skin.

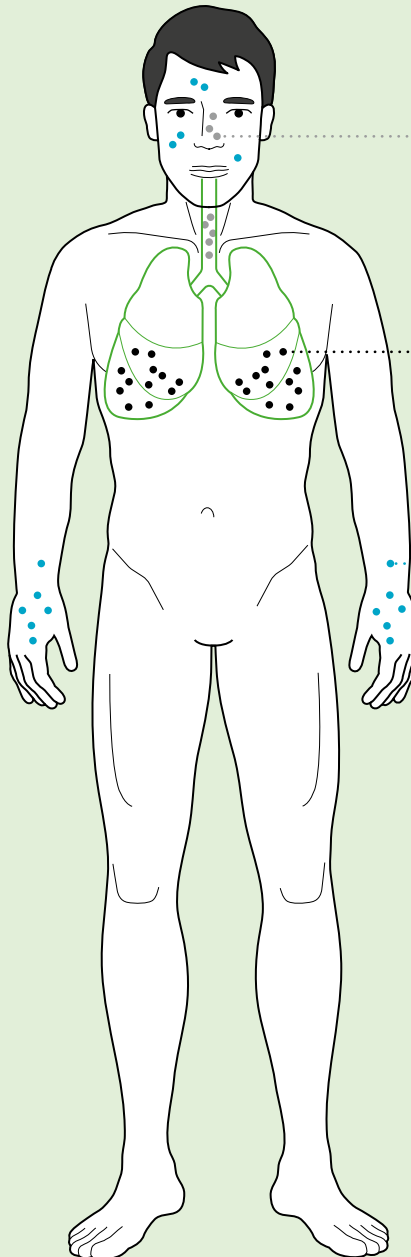

### DUST VOLUMES

Every year up to four wheelbarrows full of dust are produced in a joiner's workshop. Nobody would want to breathe in such a volume voluntarily.

## SYSTEMATIC DUST EXTRACTION

Whether you're in a workshop or on a construction site – Festool has the right extractor for every job site and every application. They are perfectly matched to your Festool tools, and with our clever accessories, your work becomes even more comfortable, safe and clean.

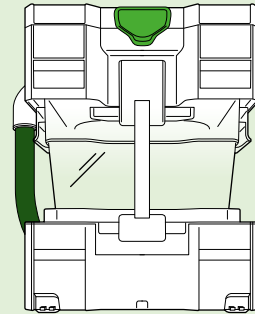

### Pre-separator for large quantities of dust

The CT-VA pre-separator ensures a constantly high suction power when there are particularly large quantities of dust or chips. Thanks to the cyclone technology, up to 95% of this is collected before it reaches the extractor (for models CT 26/36/48).



### Remote-controlled extraction

Using the CT-F I radio remote control, you can switch the extractor on and off directly at the suction hose. A second button also allows you to activate the extractor's coupling mode, so that it can be started via the **Bluetooth®** battery pack of the cordless tool.

### Ensure connection is secure

The D 27 DM-AS/CT connecting sleeve with bayonet fitting connects the suction hose and power tool securely.

### More in the hose

The conical AS/CTR suction hose, which is smooth on the outside and inside increases air flow and thus suction power. It is elastic, robust and anti-static, so that you can work flexibly and without getting caught up.

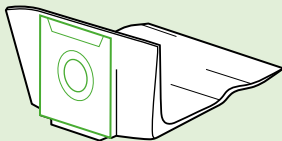

### SELFCLEAN filter bag

Prevents the formation of dust thanks to a self-cleaning effect and is sealed prior to disposal for maximum health protection.

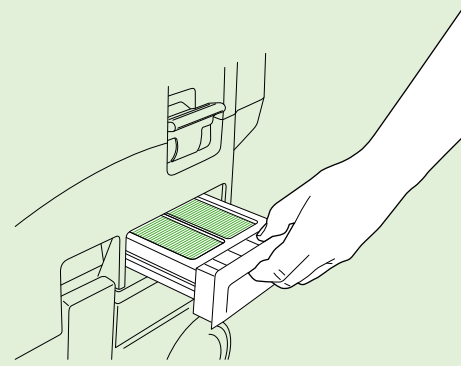
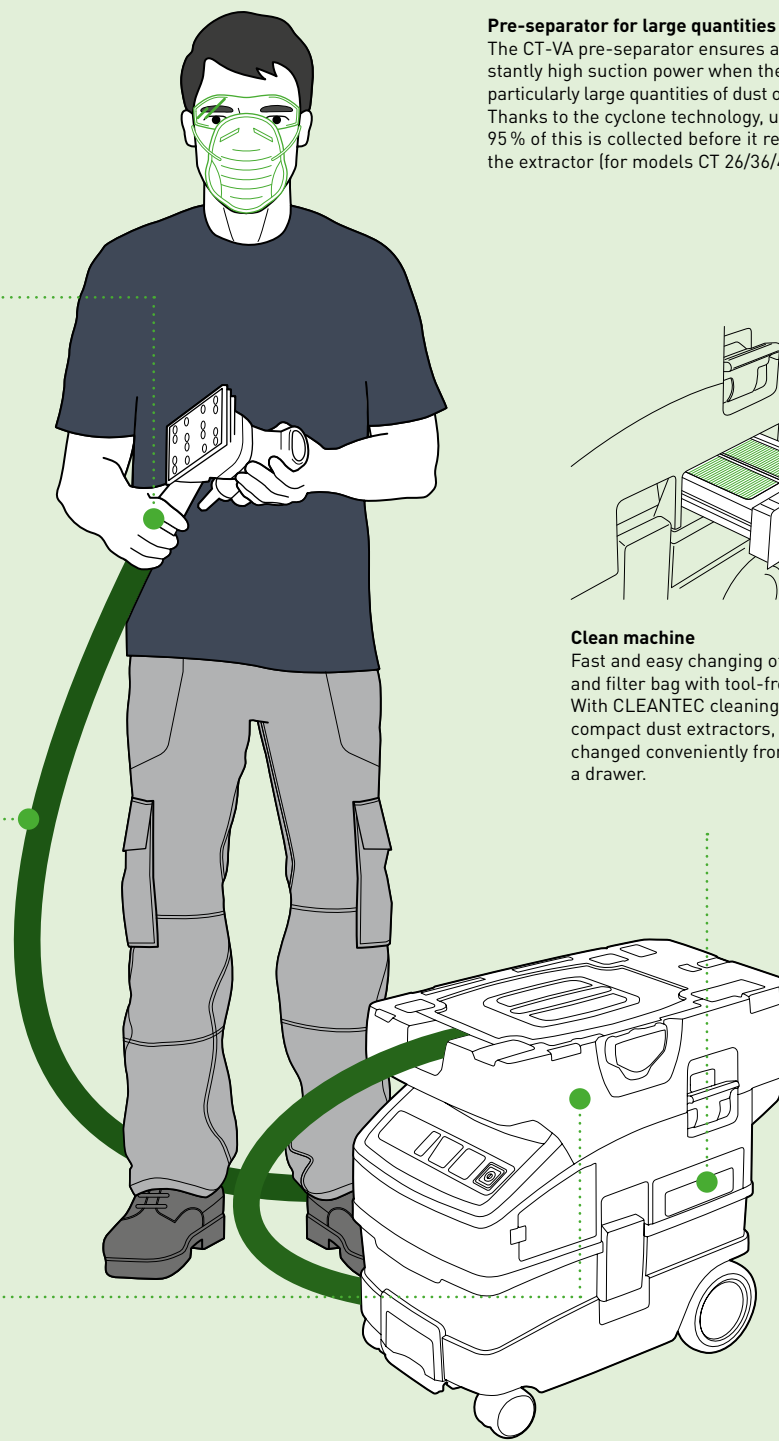

### Clean machine

Fast and easy changing of the main filter and filter bag with tool-free replacement. With CLEANTEC cleaning extractors and compact dust extractors, the filter is changed conveniently from outside via a drawer.

\* Please note that the Bluetooth® function is not available in all countries.



# FESTOOL SPOTLIGHTS

People who work with wood every single day need to be able to rely on the best tools for the job. We asked five professionals about their favourite Festool products.

Text: **Melissa Berger** | Photography: **Thomas Baumann, Torben Jäger, Sven Cichowicz, Simon-Paul Schempershofe**



**NADJA KÖRBEL**

Nadja Körbel is a Festool applications expert. When it comes to precise floor laying work, there's nothing anyone can teach her.



**MARK MAXFIELD**

The carpenter from England has been in the business for almost forty years and has many talents. And that's exactly what he likes about his Festool tools.



**CLAUS SCHWARZMANN**

The owner and boss of the company Schwarzmann Fenster GmbH from Vorarlberg, Austria, is not only an innovative window fitter, but also an avowed Festool fan.



**JAN SCHWARZMANN**

Already in his early days, the master carpenter learnt that the construction of solid wood windows depends on precision – and on the right tool.

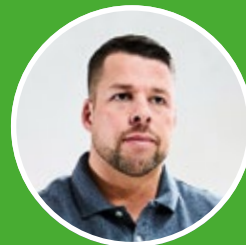

**PHILIPP STAHL**

Philipp Stahl, applications expert at Festool, is absolutely fit. Nonetheless, he swears by the ExoActive exo-skeleton for overhead work.

If you've got one, you won't want to give it up again. Why? Because with the new SYMC 70 cordless compound mitre saw, interior and exterior angles can be sawn effortlessly and precisely. On rollers. And without a cable in sight.

**"I'M IMPRESSED BY THE TIME SAVING AT EVERY WORK STEP: IT'S REALLY EASY TO ALIGN THE SAW AND THE MITRE; NO REWORK IS REQUIRED THANKS TO THE EXACT ANGLE TRANSFER."**

Nadja Körbel, Festool applications expert

# SYMC 70



49

## THE NEW CORDLESS COMPOUND MITRE SAW

- › **One setting, one corner.** The symmetrical stop system enables you to effortlessly saw strips for interior and exterior angles with just one setting.
  - › **Greater flexibility means greater efficiency.** The rollers allow you to quickly and easily align the machine to yourself and the strips. This means that you can work comfortably with maximum efficiency even in small spaces.
  - › **Well-thought-out.** The simple operating concept, the LED spotlight and the improved extraction optimise the work process for you.
- » [festool.com/@577464](https://www.festool.com/@577464)



T-shape or C-shape? That's still a question of taste for professionals. Anyone who doesn't want to miss out on 18 V power even in the handy format will be impressed by the new CXS 18 and TXS 18 cordless compact screwdrivers.

**“WHEN INSTALLING WOODEN FIXTURES IN OLD WALLS, YOU HAVE TO WATCH OUT THAT THEY DON'T BEND OUT OF SHAPE. WITH THE CXS 18 AND THE ANGLE ATTACHMENT, I CAN GET TO WORK WHEREVER I WANT.”**

Mark Maxfield, owner of Maxfield's, Witney, England

# CXS/TXS 18



## THE COMPACT SCREWDRIVER WITH 18 V BATTERY POWER

- › **Compact and surprisingly powerful.** The compact CXS/TXS 18 cordless screwdrivers provide a full 18 V power output for easy drilling, screwdriving, angle drilling and angle screwdriving.
- › **Attachments for every application.** The 18 V compact screwdrivers are really flexible, and tool changes are quick and easy thanks to the CENTROTEC System and FastFix interface.
- › **Fully equipped.** With a magnetic bit holder, belt clip and switch-activated LED lighting that can also be controlled via the Work App\* in combination with a Bluetooth®\* battery pack.
- › [festool.com/@576883](https://www.festool.com/@576883) (CXS 18)
- › [festool.com/@576895](https://www.festool.com/@576895) (TXS 18)

\* Please note that the Festool apps and the Bluetooth® function are not available in all countries.





**“EXTREMELY HANDY AND ON POINT WHEN IT COMES TO POWER – THE NEW TXS 12 WITH THE SMALL BATTERY PACK IS EXACTLY RIGHT FOR OUR FINE WOODEN WINDOW.”**

Claus Schwarzmann, Owner of Schwarzmann Fenster GmbH, Schopponau, Austria

# CXS/TXS 12



The new CXS 12 and TXS 12 cordless screwdrivers are the uncrowned heroes among the compact screwdrivers. Especially in tight spots and complicated corners, they prove to be sovereign problem solvers. Some would call it ingenious. We call it a reduced workload.

#### **THE NEW COMPACT SCREWDRIVER WITH 12 V BATTERY POWER**

- › **Powerful in the smallest of spaces.** In places nothing else can reach, our smallest cordless compact screwdrivers CXS 12 and TXS 12 get to work powerfully.
  - › **Small but surprisingly powerful.** Our new 12 V compact screwdrivers score points with perfect handling and plenty of power – especially for mobile installation jobs.
  - › **Compact and compatible.** The compact 12 V battery packs are compatible with all chargers from the 18 V cordless portfolio. The attachments for the 18 V screwdrivers also fit perfectly.
- » [festool.com/@576864](https://festool.com/@576864) (CXS 12)  
» [festool.com/@576873](https://festool.com/@576873) (TXS 12)

Extremely versatile, precise and easy to handle: The OF 1010 R is the ideal machine for fine routing work. Whether you guide it freely or use the guide rail – with our compact router, you can achieve perfect results when profiling, grooving, rebating and dovetailing.

**“THE COMPACT ROUTER IS REALLY FUN, BECAUSE IT’S UNBELIEVABLY PRECISE AND VERSATILE. WITH THE NEW LIGHTING RING, YOU CAN SEE THIS CLEARLY EVEN AS YOU WORK.”**

Jan Schwarzmann, junior manager of Schwarzmann Fenster GmbH, Schoppernau, Austria



# OF 1010 R

## THE COMPACT ROUTER WITH LIGHT

- › **Handy and precise.** The compact router with 55 mm routing depth adjustment range and handle is ideal for precise routing. The routing depth can be adjusted to the nearest tenth of a millimetre in seconds.
  - › **Better view.** So that you can always see exactly where you’re routing, we now offer the new OF 1010 R with a lighting ring.
  - › **Extremely versatile.** Its wide range of system accessories, such as cutters, routing templates and guide rails means that the OF 1010 R’s applications are virtually unlimited.
- › [festool.com/@578005](https://www.festool.com/@578005)





**“THE EXOACTIVE IS TRULY  
REVOLUTIONARY, BECAUSE IT  
NOT ONLY RELIEVES THE  
STRAIN ON US TRADESPEOPLE  
DURING STRENUOUS WORK,  
BUT ACTIVELY SUPPORTS US.”**

Philipp Stahl, Festool applications expert

Heavy overhead work shouldn't be taken lightly. But our new active exo-skeleton can. With the ExoActive\* you can be much more relaxed while you work. It takes the load off your neck and gives you extrapolated power when your arms get tired.



# EXOACTIVE

## ACTIVE EXO-SKELETON WITH 18 V BATTERY POWER\*

- › **Makes it easy for you.** Our active exo-skeleton with its powerful 18 V battery provides an extra power boost to give you the exact support you need during tiring overhead work.
- › **Targeted support.** The ExoActive\* gives you targeted support precisely where it's needed. You can set where you would like support and the level in a matter of seconds.
- › **Fits like a glove.** The ExoActive\* is as easy to put on as a rucksack, can be individually adapted to your height and its ergonomics perfectly tailored to you.
- › [festool.com/@577339](https://www.festool.com/@577339)

\* Please note that the ExoActive is not available in all countries.

# TALENT SHOW

At the EuroSkills and WorldSkills shows, young tradespeople demonstrate their skills. And Festool supports this new generation.

Text: **Melissa Berger** | Photography: **Sandy van der Vreken, Urszula Poniatowska, Sandra Leduc, Marcin Tomaszewski**

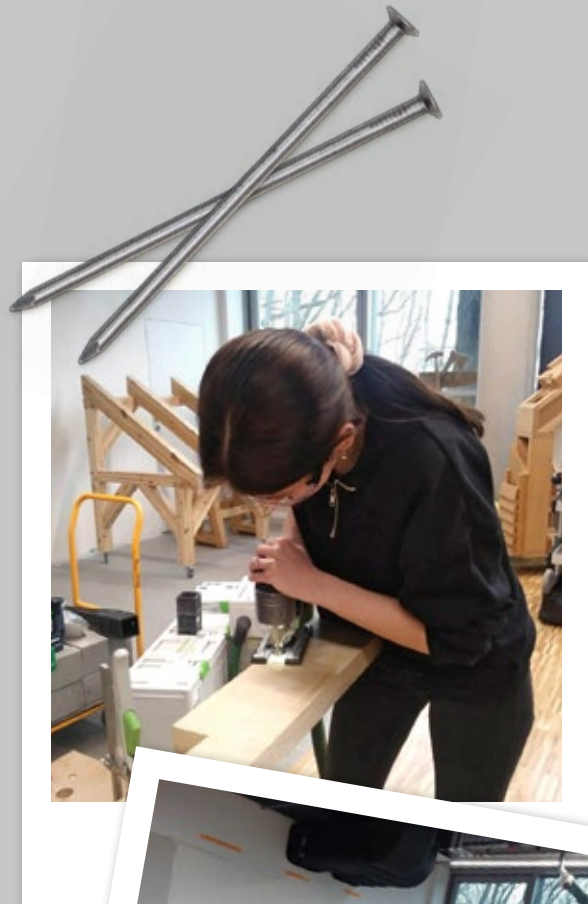

↑ Róża Olszewska and Artur Tsybran are the two Polish participants among the landscapers. Even during preparation, timber construction formed the focus of their work.

↑ The Belgian EuroSkills team with product specialist Sebastian Danet, during preparation in the Festool Training Centre.



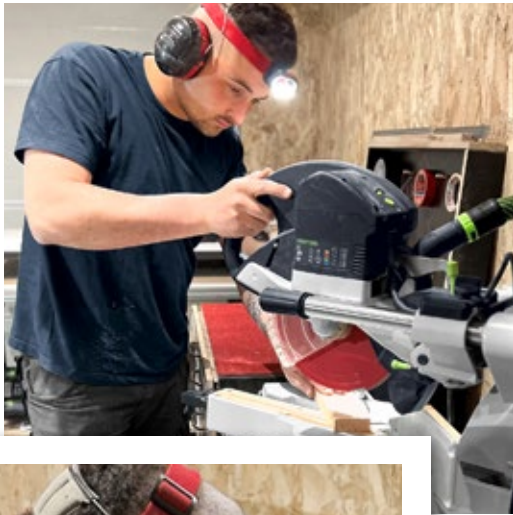

↑ Dorian Groitier represented France in the cabinet maker category.

↓ Home game for Radostaw Kropaczewski, who represented the Polish team in the joiner category.



It's amazing what the EuroSkills and WorldSkills participants can do. In the competitions in any case. But above all during preparation: They have to get through quite a number of preliminary rounds at regional and national level. They invest hundreds of hours in their training, alongside their actual jobs. The aim: To be as precise and fast as possible. It's no secret that they want to achieve the best results with tools that are as precise as they are efficient.

55

For almost 100 years, we at Festool have been supporting professionals with their trade. With the same passion, we are also supporting the new generation of experts – since 2002 this has included the best of the best, throughout Europe and throughout the world. At EuroSkills 2023, which was held in Gdansk this year, we supported the Polish team in particular. Not only with the best tools, but also with the enthusiastic support of our team in the Festool Poland training centre. The joiner Radostaw Kropaczewski was able to prepare well for the competition. Mateusz Janta represented Poland in the cabinet maker category, while Róża Olszewska and Artur Tsybran competed in the landscaper category.

Pascal Krott and Dean Theis also entered the landscaper category, but for Belgium. They were just as enthusiastic about working with Festool tools as the joiner in the Belgian team, Alain Maes, and his colleague Dorian Groitier, who represented the France team as a cabinet maker. During the preparations, they had already impressively demonstrated that they deserve their place among the best. At the time of print, the decision at European level had not yet been made ...

Stay tuned, and follow our blog to see how our young talents did at EuroSkills Gdansk:  
» [festool.com/blog](https://www.festool.com/blog)

**EuroSkills** (European Championship of Young Professionals) was held in Gdansk, Poland in September 2023 with around 400 participants from 31 countries.

The next **WorldSkills** (World Championship of Young Professionals) will be held in Lyon, France. More than 1,300 participants from over 60 countries will compete there from 10–15 September 2024.







# HEAVY BEAM



Converting or dismantling old roof trusses is like a type of time travel, but is often difficult. The new RSC 18 cordless reciprocating saw makes this type of work much easier. And it also gives you the great feeling that not everything was better before.

Text: **Ralf Christofori** | Photography: **Torben Jäger, Thomas Baumann**



# RSC 18

## OUR NEW CORDLESS RECIPROCATING SAW

- › **Powerful yet effortless.** The new RSC 18 cordless reciprocating saw with high-torque EC-TEC motor and switch-activated pendulum stroke ensures the right speed. Thanks to the unique anti-vibration system, the reciprocating saw can be guided smoothly and has an extremely low level of vibrations.
- › **Robust and flexible.** The RSC 18 is made for the toughest everyday use on construction sites – whether you're working with wood, metal or particularly abrasive and hard materials. The two-stage stroke rate limitation enables the cutting speed to be adjusted optimally to the material.
- › **Well thought-out.** The integrated LED provides optimal lighting of the work area. The special chuck enables quick, contactless changing of the saw blade. And the dust extraction device attached to the saw table extracts the dust exactly where it is created.

## FIND OUT MORE

You can find everything you need to know about our new cordless reciprocating saw on our website:  
› [festool.com/@576948](https://www.festool.com/@576948)



**H**and on heart: a cordless reciprocating saw, up to 3,000 strokes per minute and a toothed saw blade length of more than 30 centimetres – that's not normal! But that's not all that makes our new RSC 18 cordless reciprocating saw so unusual. Up here, in the roof truss, it is in its element. When girders have to be dismantled, purlins replaced and mortise joints or scar joints adjusted, the RSC 18 plays out its many qualities. It is made for the toughest everyday use on construction sites – and above all for making work easier for professionals even on the toughest jobs.

### For your most powerful sawing applications

The new RSC 18 is strong, fast and super-robust. With the right saw blades, solid wood or other wood materials and composites can be cut quickly and easily. With its brushless EC-TEC motor and switch-activated pendulum stroke, the reciprocating saw gets to work extremely powerfully. The powerful and smart 18 V battery power from Festool ensures that it doesn't run out of juice. The full power goes to the saw blade and the unique anti-vibration system reduces the machine's vibration by 40 percent.

Whether in conversion or dismantling work, roof truss conversion or window fitting – with the RSC 18 you can work significantly more effectively and with noticeably less fatigue. The saw blade can be rotated by 180°, making it possible to saw up to the wall, ceiling or floor without any problems. The RSC 18 is also the only cordless reciprocating saw with an extraction adapter. During overhead work in particular, it ensures that you are not exposed to dust. The 18 V Bluetooth®\* batteries, also included in the scope of delivery, can be combined perfectly with the extractor remote switch-on; machine on, extractor on. You can neatly store your RSC 18 including all the accessories in the Systainer so that they are always quick to hand.

### For your ears

It's hard to avoid things getting loud when using tough machines. But in any case, you must prevent the possibility of this damaging your ears. That's why you need our brand new multifunctional GHS 25 I ear protection. It is multifunctional because it protects you against noise during your work, but allows you to make telephone calls via Bluetooth® or listen to your favourite music in outstanding sound quality. The GHS 25 I blocks loud ambient noise outside of the safe sound level of 79 dB (in accordance with EU standard EN352). Thanks to the innovative conversation mode, you can speak to your colleagues at any time without having to remove the ear protection. Understandable telephone calls are also guaranteed. That's not just cool, it's simply phenomenal.



# GHS 25 I

59

### THE ULTIMATE MULTIFUNCTIONAL EAR PROTECTION

- › **Protects your ears.** With our multifunctional ear protection, you can listen to music or make phone calls in excellent sound quality – while at the same time relying on the advantages of professional ear protection.
- › **Allows speech through.** The innovative microphone technology ensures you only hear what you want to hear. Conversation mode enables communication with colleagues without removing the ear protection.
- › **For good conversation.** With the GHS 25 I ear protection, you don't have to sacrifice anything: listen to your music or accept telephone calls via Bluetooth®. The sound-insulated microphone ensures that you can communicate clearly during telephone calls.

### FIND OUT MORE

You can find out all about our innovative multifunctional ear protection on our website:  
› [festool.com/@577792](https://www.festool.com/@577792)

## #festoolme

Follow us on Instagram.

 [instagram.com/festool](https://www.instagram.com/festool)

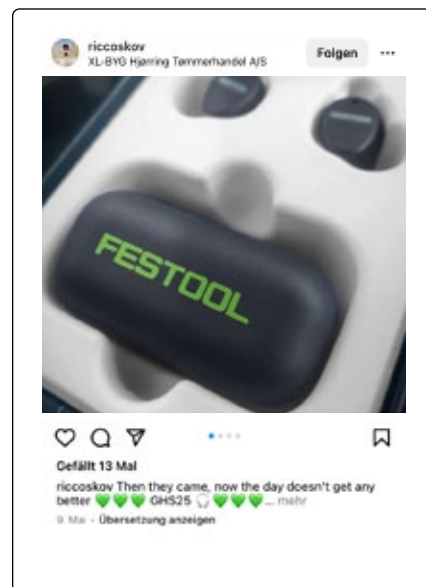

\* Please note that the Bluetooth® function is not available in all countries.



# THE POWER

Festool is going its own cordless way. Out of conviction and for good reason. Our battery packs in the Festool system are perfectly matched to the tools and product families. That's why they simply have to be able to do more.

Text: Ralf Christofori | Photography: Thomas Baumann, Torben Jäger, Alma Colbazi-Rebmann, Roger Nellsjö

# OF FESTOOL



# Tailor-made.

## Integrated and ergonomic solutions.

62

**T**here's never been so much cordless power in one small package. The share of cordless tools in the total volume of power tools produced worldwide is currently around 50 percent, in some countries even more. They make the job much easier and lighten the load, offering the persuasive benefits of unrestricted mobility and freedom of movement. Of course, Festool also offers an extensive range of 18 V products. But for us, the crucial thing is that every battery solution in the system is optimally designed. The ideal cordless tool should be powerful, long-lasting and robust, but also light, handy, perfectly balanced and, ideally, also intelligent.

These are the qualities that matter. But because tools handle all different types of work, one battery for all doesn't make any sense. On the one hand, "customised" means that all our battery packs are fully compatible with "old" power tools in the Festool 18 V system that are already available. This is really important to us, so that you can continue to power your tools with plenty of "juice" for several generations to come. On the other hand, it's also important to take the shape of the tools into account as well as the specific application situation. A compact one-handed sander with which you can easily, comfortably and effortlessly work overhead has quite different requirements than, for example, our new CSC SYS 50 cordless bench-mounted circular saw.

For example, our latest generation of 4.0 Li-HighPower Compact battery packs are powerful enough for any application, because we have reduced the weight but not the power. The Ergo battery pack was specially developed for the ETSC 125, RTSC 400, DTSC 400 cordless sanders – literally built for manual operation: It sits in the handle and weighs less than 600 grams. The 8.0 Li-HighPower battery pack, currently the most powerful and long-lasting member of the Festool battery family, is brand new.



**"OUR DEVELOPMENT AIMS SPECIFICALLY TO ACHIEVE CUSTOMISED BATTERY SOLUTIONS – CUSTOMISED FOR OUR MACHINES AND TAILORED TO THE SPECIFIC REQUIREMENTS OF OUR CUSTOMERS."**

Tobias Pauli  
Verification Battery team leader

➤ Tobias Pauli, Verification Battery team leader (left), and Stefan Scharpf, Cordless Technology team leader, are among the Festool cordless experts.

# -50%



**Never before has strong performance been so compact**  
The 4.0 Li-HighPower Compact battery pack is so small that it even leaves room to work in tight spaces. It is half as big as the standard 5.0 Ah battery pack but offers the same level of performance.

**EVERYTHING IT TAKES.**  
**CUSTOMISED FOR EVERY**  
**APPLICATION.**

# -20%



**Never before has strong performance been so ergonomic**

The Ergo battery pack was specially developed for the ETSC 125, RTSC 400, DTSC 400 cordless sanders. It sits in the handle, weighs less than 600 grams and is therefore 20% lighter than a standard 5.0 Ah battery pack.



# +60%

**Never before has performance been so high**  
The brand new 8.0 Li-HighPower battery pack provides maximum power and endurance (with a 60% longer runtime than a 5.0 Ah standard battery pack), even for heavy-duty applications.



**UNCOMPROMISING PERFORMANCE**

With our warranty all-inclusive\*, not just your tools but also all batteries and chargers are fully covered: a full repair\*\* is completely free of charge in the first three years – this also applies to battery packs and chargers. See page 67 for terms and conditions, explanations and additional information.







Mark Maxfield uses the SYS-PowerStation when working with the HK 85 and the extractor. The TCL 6 DUO rapid charger is in use almost around the clock.

## Powerful.

Power and endurance for every application.

**W**hile it's certainly true that power is what matters for cordless tools, a distinction has to be made here: Some machines need rapid strength, while others need adequate power and running time. In products for heavy duty applications, such as the KAPEX KSC 60 cordless sliding compound mitre saw or the TSC 55 cordless plunge-cut saw, our double battery concept has proven its worth. In handier tools, such as the CARVEX PSBC 420 cordless pendulum jigsaw or the new RSC 18 cordless reciprocating saw, sufficient power and running time are provided by a single 5.0 or 8.0 battery pack. This means you can truly rely on an optimally designed battery solution in every work situation.

The further development of lithium-ion cell technology has successively increased the power and runtime of battery packs and will enable new battery product groups in future too. But power and runtime are not dependent on the battery alone. That's why we are further developing the Festool battery system as a whole. This includes the intelligent motor control and power electronics as well as the development of rapid chargers with integrated cooling device. Our AIRSTREAM concept ensures that you can charge your batteries as quickly as possible and can therefore work without interruption. Powerful and long-lasting – including under maximum load. All this is only topped by our mobile SYS-PowerStation that stores 1500 watt-hours of energy – for most applications, that is enough for an entire working day.

# Intelligent.

## Digital operation and communication.

**W**e are of the opinion that a battery shouldn't simply be the most powerful supplier of power, but can be much more. Our Bluetooth®\* battery packs are intelligent and can even communicate. You can use them to switch a mobile dust extractor on and off in Auto-Start mode. The Bluetooth®\* battery is also the IoT intermediary between the tool and your smartphone. Via the Work App\*, you can retrieve the charge status and locate the battery. The crucial thing is that we keep our intelligent batteries fit for future applications by applying updates. This means there are no obstacles on your journey to the future.



You can find out all about the Festool 18 V cordless system on our website.

**“WE STAND FOR THE FESTOOL SYSTEM, IN WHICH EVERYTHING IS COORDINATED. THIS IS A UNIQUE SELLING POINT AND A CUSTOMER BENEFIT THAT PLAYS A CENTRAL ROLE EVEN IN OUR INTELLIGENT BATTERY SOLUTIONS.”**

Sascha Menges  
CEO of Tooltechnic Systems (TTS)

\* Please note that the Bluetooth® function and the Festool apps are not available in all countries.



# FS/2- SET



**Precision along the whole length**  
With the self-aligning FSV/2 connecting pieces, the guide rails can be connected quickly and conveniently – for precise and even cuts along the entire length.



**Precision for every angle**  
The FS-WA angle stop can quickly be attached to the guide rail without tools. This guarantees precise and repeatable angled cuts from  $-60^\circ$  to  $+60^\circ$ .

## EVERYTHING THAT MAKES THE FS/2 GUIDE RAIL EVEN BETTER

We have put together all the most important items in the accessories set for the FS/2 guide rail: an angle stop, two connecting pieces, a deflector, the kickback stop and two indispensable fastening clamps, with which the guide rails are securely fastened. Although these helpers are actually all indispensable. With the adjustable angle stop, you can achieve precise angled cuts of  $-60^\circ$  to  $+60^\circ$ . The self-aligning connecting pieces ensure stable connections, even with two or more connected rails. The deflector prevents the suction hose and cable from getting caught up on the end of the guide rail. And the kickback stop minimises the risk of the saw kicking back and rising up. In the FS/2 set, you have all this close to hand in the Systainer<sup>3</sup>.

» Find more useful information and accessories from Festool at: [festool.com/accessory](https://www.festool.com/accessory)

**“IN MY WORKSHOP**

**CABLES HAVE HAD THEIR DAY.”**

**@CHARLES: OUR 18 V**

**PORTFOLIO HITS THE RIGHT BUTTON.**



**FESTOOL**

[festool.com/inspired-by-craftspeople](https://festool.com/inspired-by-craftspeople)



70786 1P/en  
4 014549 434345