

# BLUEPRINT

SPECIAL NO. 1



## FESTOOL

## DIY Sofa Bed

Comfortable, flexible and at the same time equipped with a lot of smartly used storage space - that's how maker Laura Kampf describes the perfect sofa bed.

With a lot of creative energy and her usual skill, she fulfills this wish and, of course, the right tools are not to be missed. This time, the Festool TSC 55 plunge-cut saw, the OF 1010 router and the TID 18 cordless screwdriver are among the tools on hand.

# Clever folding sofa bed by Laura Kampf

This clever sofa bed by Laura Kampf converts from sofa to bed in seconds. The backrest doubles as storage for the bedspread and pillow and can be folded up and stored in the back when in bed mode. This construction plan deliberately omits the specification of connection types. For concealed connections, for example, Festool Domino dowels can be used. Alternatively, everything can

simply be screwed together. In the original, the screws are countersunk and covered with dowels. Before assembly, prepare all individual parts according to the dimensional sketches at the end of these instructions. In the step-by-step instructions, the component to be assembled is colored green.



1

1.1

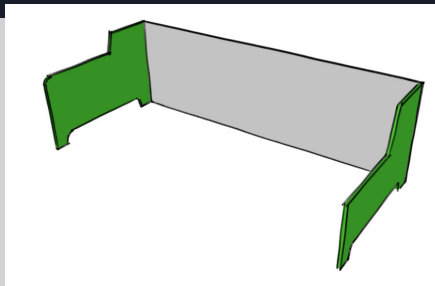

Start with the construction of the body. The next components will be mounted in it. Refer to the dimensional sketches for the respective positions. In the first step, connect the two side panels (I, J) to the rear panel (R).

1.2

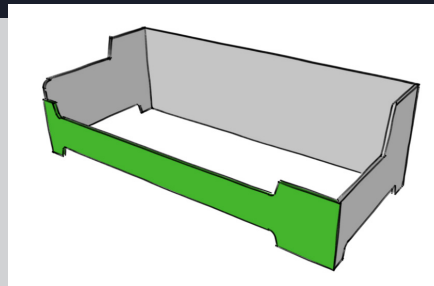

The front side (A) is provided with a rebate of half the material thickness on the left and right and then joined to the side panels.

1.3

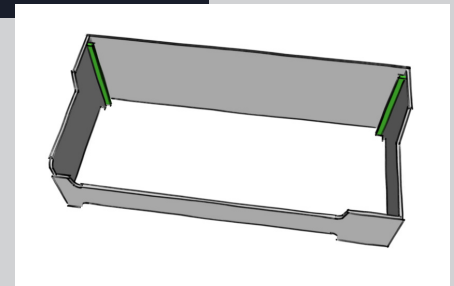

Now mount the vertical strips (P) on the side panels, behind which the lid can later be inserted. They are offset downward by the material thickness of the lid and stand up at the bottom. The distance between the strips and the rear wall is 4.6 cm.

2

2.1

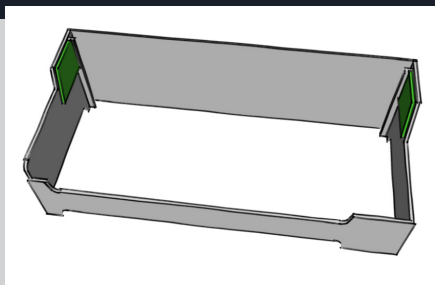

In sofa mode, the lid rests on these two parts (Q), which are mounted on the outer sides. Make sure that they are offset backwards and downwards by the material thickness of the lid so that the lid closes flush later.

2.2

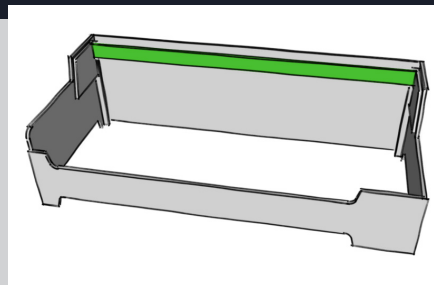

To prevent the lid from sliding down, it rests on this horizontal element (F) with a ledge. Connect it to the vertical strips mounted in step 1.3, with which it is flush at the top.

2.3

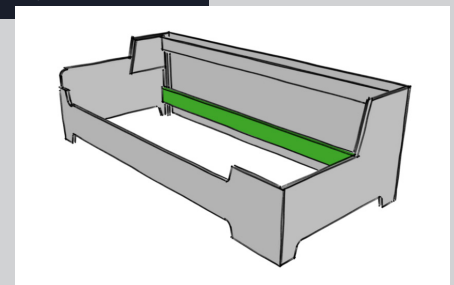

Now the rear support for the slatted frame (D) can be mounted. It is also connected to the vertical battens from step 1.3.

## 3

3.1

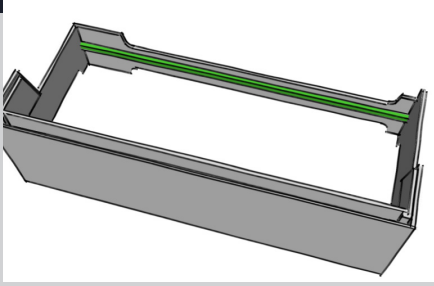

The front support of the slatted frame (E) is connected to the front (A). It is at the same height as the rear support (D). Otherwise, you would constantly roll to the side.

3.2

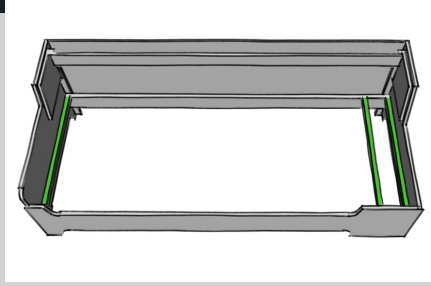

Now the left slatted base (N) is connected to the left side part (I). On the right side, the book shelf separates the slatted base from the side part. The support strip (N) is mounted accordingly at the position indicated in the dimensional sketches between the front side (A) and the rear slatted base support (D). Two more slats (N), one on the right outside (J) ...

3.3

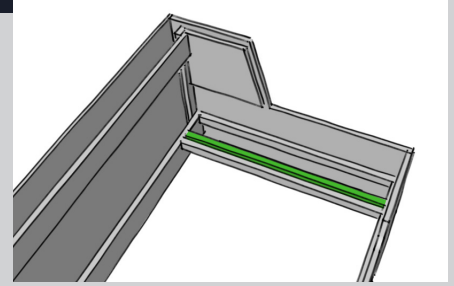

... and another (O) between the front (A) and rear slatted support (D) serve as a base for the book shelf.

## 4

4.1

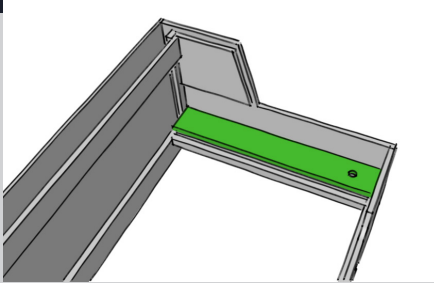

Now the bottom of the book shelf (K) can be mounted in its position.

4.2

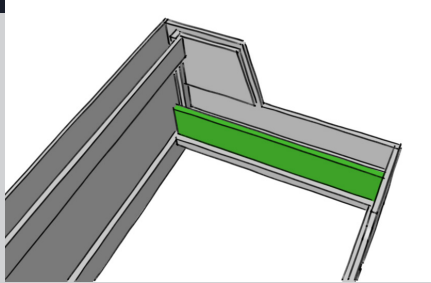

This element (L) closes the bookrest to the mattress. It is laterally connected to the bottom of the book shelf. It is inserted from above between parts (N) and (O). A corner must be cut out at the front for this, because otherwise the front slatted base support (E) would be in the way.

4.3

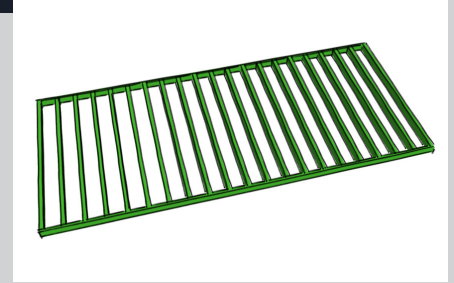

Now mount the 21 short (M) and the two long slatted frame parts (H) outside the bed.

## 5

5.1

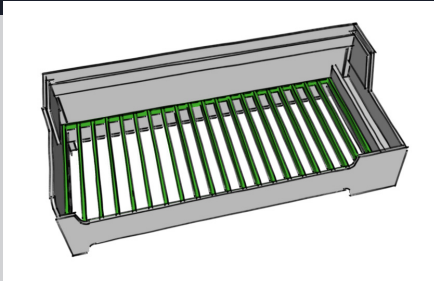

Place the slatted frame in the bed. It rests on the supports assembled in steps 2.3 to 3.2 and does not need to be connected to the bed.

5.2

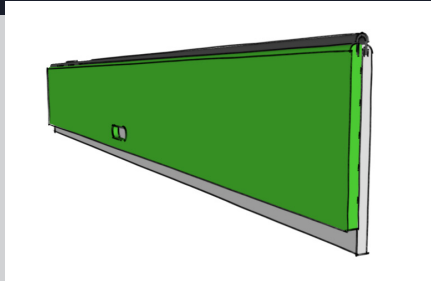

Saw or mill a groove in the two parts of the lid (B, C) and connect them with a strong fabric or an old lashing strap, either by gluing it into the grooves (for example, with epoxy resin) or by fixing it from the inside of the lid with short screws. A recessed grip in the front part of the lid makes it easier to open.

5.3

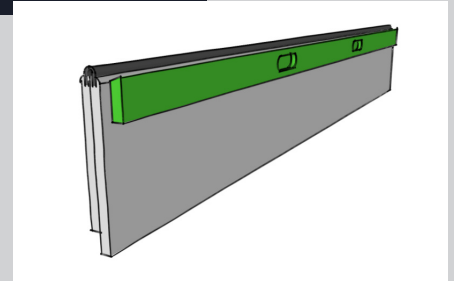

This strip (G) serves as a handle to allow the lid to be pushed securely into the storage compartment when folded. Mill two recessed grips and connect the strip to the top of the lid (B) from below. The side facing the lashing strap hinge must be provided with an angle of 15 degrees.

Body - front view

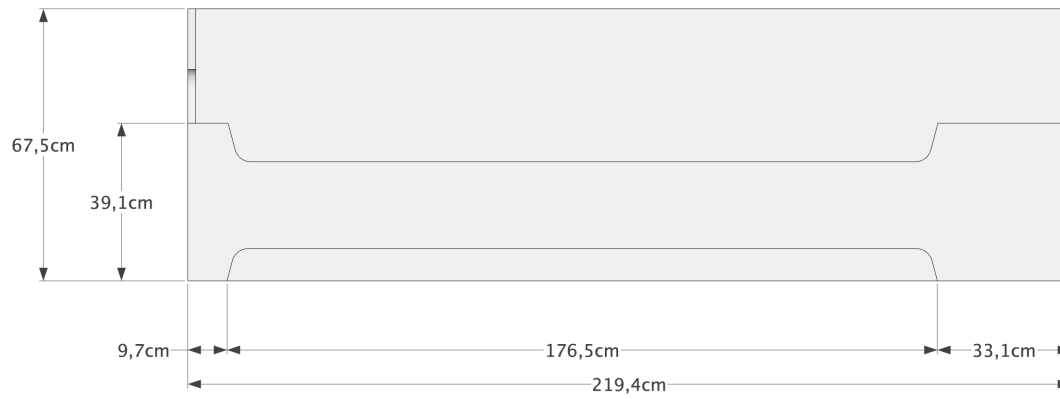

Body - view from the right

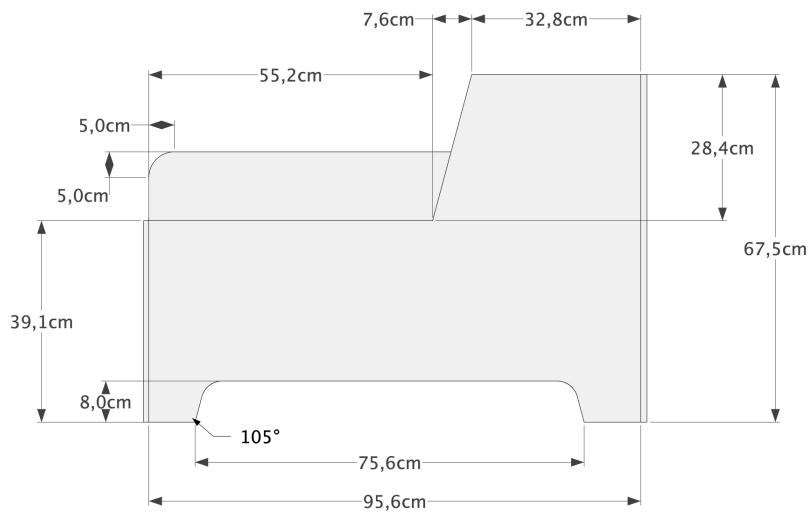

Body - view inside left

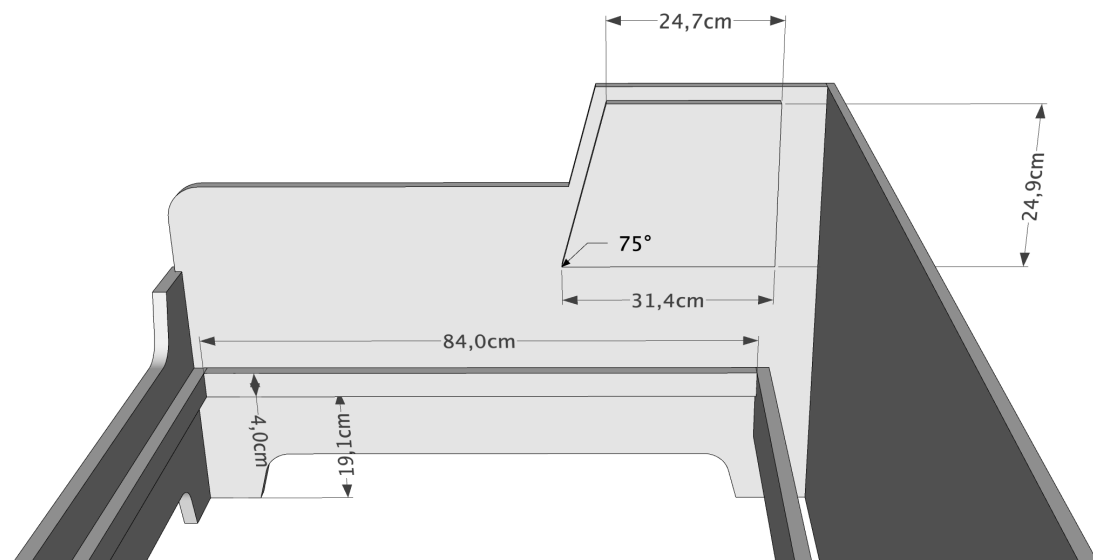

Body - view inside right

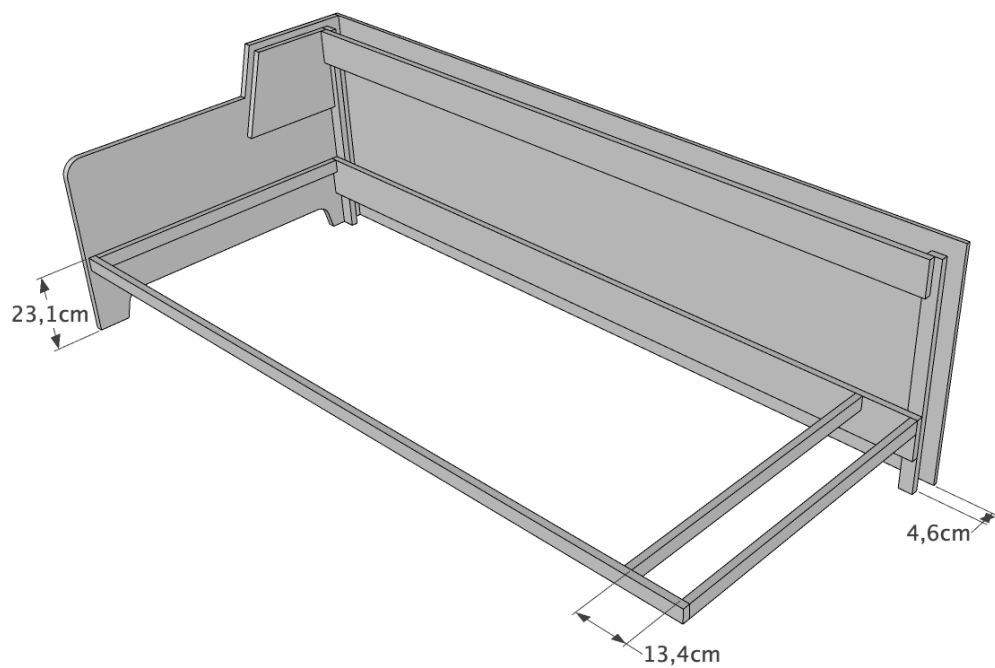

Body - view inside bottom

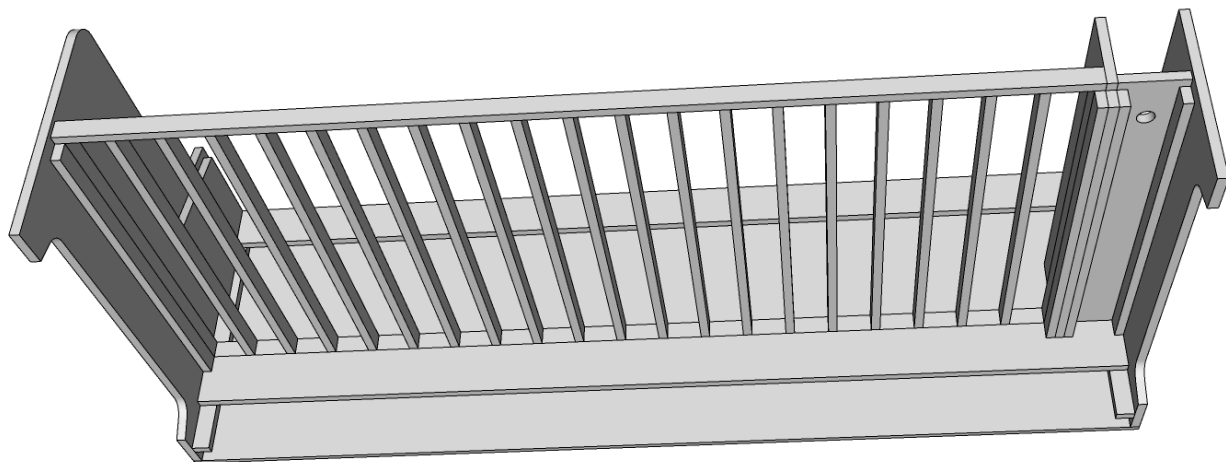

Plywood, 20mm				
No.	Name	Quant.	Ready made	
			L	W
<b>A</b>	Body front	1	219,4cm	39,1cm
<b>B</b>	Lid front	1	215,4cm	30,5cm
<b>C</b>	Lid top	1	215,4cm	26,7cm
<b>D</b>	Rest slatted frame back	1	215,4cm	12,0cm
<b>E</b>	Rest slatted frame front	1	215,4cm	4,0cm
<b>F</b>	Separation lid compartment lid rest	1	211,4cm	10,0cm
<b>G</b>	Cover rest bar	1	210,4cm	7,5cm
<b>H</b>	Slatted frame long	2	200,0cm	4,0cm
<b>I</b>	Body left	1	95,6cm	67,5cm
<b>J</b>	Body right	1	95,6cm	67,5cm
<b>K</b>	Bookcase bottom	1	88,0cm	13,4cm
<b>L</b>	Bookcase side panel	1	86,0cm	20,0cm
<b>M</b>	Slatted frame short	21	84,0cm	4,0cm
<b>N</b>	Rest slatted frame short side	3	84,0cm	4,0cm
<b>O</b>	Rest bookcase	1	84,0cm	4,0cm
<b>P</b>	Separation lid compartment slide-in	2	65,5cm	4,0cm
<b>Q</b>	Lid rest	2	31,4cm	24,9cm

Plywood, 12mm				
No.	Name	Quant.	Ready made	
			L	W
<b>R</b>	Body back	1	219,4cm	67,5cm

